

Body and Equipment Guideline



Metris - Model Designation 447

Edition MY2022

Mercedes-Benz USA, LLC



1	Introduction.....	5	3.4.1	QR code rescue sticker	34
1.1	Purpose of Body and Equipment Guideline.....	6	3.5	Vehicle stability.....	35
1.2	Conventions.....	7	3.6	Tires	36
1.3	Vehicle safety	8	3.7	Threaded and welded connections	37
1.4	Operational safety.....	9	3.7.1	Threaded connections.....	37
1.5	Note on copyright	9	3.7.2	Welded connections.....	38
2	General	10	3.8	Soundproofing	40
2.1	Advice for upfitters.....	10	3.9	Maintenance and repairs.....	41
2.1.1	Certificate of non-objection.....	11	3.9.1	Storing the vehicle	41
2.1.2	Legal claims.....	11	3.9.2	Battery maintenance and storage	42
2.2	Product and vehicle information for upfitters..	12	3.9.3	Work before releasing the modified vehicle..	42
2.2.1	Upfitter Portal	12	3.10	Special equipment	44
2.2.2	Information for upfitters	12	3.11	Adhesive films on the exterior	45
2.2.3	Workshop Information System (WIS).....	12	4	Technical limit values for planning	47
2.2.4	XENTRY Kit	13	4.1	Limit values for the basic vehicle	47
2.2.5	Regulatory overview	14	4.1.1	Steerability	47
2.2.6	Emissions and safety information	15	4.1.2	Maximum permissible position of the center of gravity.....	47
2.2.7	Vehicle safety standards information	15	4.1.3	Maximum vehicle dimensions.....	47
2.2.8	Exhaust emission control information	16	4.1.4	Areas where welding is not permitted	47
2.3	Product safety and product liability.....	17	4.1.5	Areas of non-drilling.....	48
2.3.1	Product safety.....	17	4.1.6	Service lift support points	49
2.3.2	Product liability	17	4.2	Limit values for the suspension	50
2.3.3	Safety-relevant features	17	4.2.1	Permissible axle loads.....	50
2.4	Guarantee of traceability	18	4.2.2	Approved tire sizes.....	51
2.5	Trademarks	19	4.2.3	Diameter of turning circle.....	51
2.5.1	The Mercedes-Benz brand in interaction with external upfitters	19	4.2.4	Modifications to the axles	51
2.5.2	The function of a brand	19	4.2.5	Modifications to the steering.....	51
2.5.3	Trademark protection.....	19	4.3	Limit values for the body-in-white	52
2.5.4	Trademark rights.....	19	4.3.1	Modifications to the body-in-white.....	52
2.5.5	Advice on applying Mercedes-Benz trademarks to vans	20	4.3.2	Roof/roof load.....	52
2.5.6	Use of Mercedes-Benz trademarks.....	20	4.3.3	Limit values for the attachment point	52
2.5.7	Brand separation/identity	20	4.4	Limit values for electrics/electronics	53
2.5.8	Trademark communication.....	21	4.4.1	Fuses.....	53
2.6	Accident prevention	22	4.4.2	Vehicle position lamps and side marker lamps	53
2.7	Reprocessing of components - recycling.....	23	4.5	Limit values for additional assemblies.....	53
2.8	Quality system	24	5	Damage prevention	54
3	Planning of bodies.....	25	5.1	Brake hoses/cables and lines	54
3.1	Selecting the basic vehicle	26	5.2	Welding work	55
3.1.1	Vehicle and model designation.....	26	5.3	Anti-corrosion protection measures.....	57
3.1.2	Model overview.....	28	5.4	Painting work/preservation work	59
3.2	Vehicle modifications	29	5.4.1	Application of decals.....	60
3.3	Dimensions and weights.....	30	6	Modifications to the basic vehicle.....	61
3.3.1	Weight limits	32	6.1	Suspension.....	61
3.4	Vehicle identification data	33	6.1.1	General information on the suspension.....	61

6.1.2	Springs/shock absorbers.....	62	8.3.1	Main battery	97
6.1.3	Brake system	62	8.3.2	Auxiliary battery	97
6.1.4	Air suspension	64	8.3.3	Support battery (code E34).....	99
6.1.5	Wheels/tires.....	64	8.3.4	Backup battery.....	99
6.1.6	Spare wheel	65	8.3.5	Battery maintenance and storage	99
6.2	Body-in-white/body	66	8.4	Interfaces/electric lines.....	100
6.2.1	General information on the body-in-white/ body	66	8.4.1	Electric lines	100
6.2.2	ISO conformity of partition.....	67	8.4.2	Cable extension	100
6.2.3	Side wall, windows, doors and flaps	69	8.4.3	CAN bus and networking.....	101
6.2.4	Fenders and wheel wells	70	8.4.4	Connecting additional electrical consumers	101
6.2.5	Underfloor paneling.....	70	8.4.5	Power tapping via terminal strip.....	102
6.2.6	Modifications to the roof structure	70	8.4.6	Retrofitting an alternator	103
6.3	Engine peripherals/drivetrain.....	72	8.4.7	Speed signal	103
6.3.1	Fuel system	72	8.4.8	Travel distance signal	104
6.3.2	Exhaust system.....	73	8.5	Illumination	105
6.3.3	Engine cooling	75	8.5.1	Adjusting the headlamps.....	105
6.3.4	Intake air system.....	75	8.5.2	Covering of illumination equipment.....	106
6.3.5	Propeller shafts.....	75	8.5.3	Vehicle position lamps/clearance lamps ...	106
6.4	Interior.....	76	8.5.4	Exterior lamps.....	106
6.4.1	General information	76	8.5.5	Interior lamps.....	107
6.4.2	Safety equipment.....	77	8.6	Mobile communications systems.....	109
6.4.3	Seats.....	82	8.6.1	Equipment	109
6.4.4	Reducing interior noise.....	83	8.6.2	Antenna connection and cable routing (radio communication)	109
6.4.5	Ventilation	84	8.7	Driving assistance systems	110
6.5	Additional assemblies	84	8.7.1	Electronic Stability Program (ESP®)	111
6.5.1	Auxiliary heating	84	8.7.2	Crosswind Assist.....	112
6.6	Attachments	85	8.7.3	COLLISION PREVENTION ASSIST and DISTRONIC PLUS assistance systems.....	113
6.6.1	Attachment above cab	85	8.7.4	Blind Spot Assist.....	114
6.6.2	Roof luggage racks	85	8.7.5	Lane Keeping Assist.....	115
6.6.3	Shelf systems	85	8.7.6	Rain sensor / Automatic headlights.....	116
6.6.4	Trailer coupling	90	8.7.7	Tire pressure loss detection system.....	116
7	Design of bodies.....	91	8.7.8	Parking assistance systems.....	117
7.1	Modifications to the interior	91	8.8	Parameterizable special module PSM (MPM)	119
7.1.1	Modifications in the cockpit area.....	91	8.8.1	PSM (MPM) functions	120
7.1.2	Retrofitting seats	91	8.8.2	PSM (MPM) interfaces	121
7.2	Refrigerated vehicles/temperature- controlled vehicles.....	92	8.8.3	ABH CAN.....	122
7.3	Vehicles for transportation of technical gases.....	92	8.9	Automatic start/stop system	123
7.4	Recreational vehicles	93	8.10	Electrical circuit diagrams	123
7.5	Retrofitting a pop top roof.....	94	8.11	Connectivity solutions <i>Mercedes me connect</i>	124
7.6	Roof height increase	94	8.11.1	<i>Mercedes me connect</i> for personal use.....	124
7.7	Government vehicles.....	94	8.11.2	<i>Mercedes me connect</i> for business use	124
8	Electrics/electronics	95	8.12	Telematics	125
8.1	General information	95	9	Calculations.....	126
8.2	Electromagnetic compatibility (EMC)	96	9.1	Center of gravity	126
8.3	Battery.....	97	9.1.1	Determination of the center of gravity in the x-direction	126

Contents

9.1.2	Determination of the center of gravity in the z-direction	128
-------	---	-----

10 Technical details..... 132

10.1	Vehicle data.....	132
------	-------------------	-----

Index..... 134

List of abbreviations..... 136

This Body and Equipment Guideline (BEG) provides upfitters and converters, hereinafter referred to collectively as "upfitters", with important technical information which must be observed in the planning and production of a safe and roadworthy body. The attachments, bodies, equipment or modifications installed and implemented by the upfitter are subsequently referred to as "upfit work".

This Body and Equipment Guideline (BEG) is based on the development of the Metris vehicles - BM 447, for the U.S. and Canada market.

Please refer to the Upfitter Portal for the Body and Equipment Guideline (BEG).

www.UpfitterPortal.com

Due to the large number of upfitters and body types, Mercedes-Benz cannot take into account all the possible modifications to the vehicle, e.g. performance, stability, load distribution, center of gravity and handling characteristics, that may result from upfit work. For this reason, Mercedes-Benz can accept no liability for accidents or injuries sustained as a result of such modifications to your vehicles. The upfitter undertakes to ensure that their body modifications are free from defects - including with regard to the overall vehicle - and do not cause danger to persons or property. If this obligation is violated in any way, the upfitter shall assume full product liability.

This Body and Equipment Guideline (BEG) is aimed at professional upfitters. As a result, BEG assume that the upfitter has suitable background knowledge.

Moreover, the upfitter must adhere to the operator's manual valid for the respective vehicle. Please be aware that certain types of work (e.g. welding work on load-bearing components) may only be carried out by appropriately qualified personnel. This will avoid the risk of injury and will attain the degree of quality required for the vehicle upfit.

The BEG provides upfitters with engineering and technical data for educational and informational purposes only. The specifications and descriptions contained in this book are believed to be accurate at time of publication. Nevertheless, upfitters should consult with legal counsel to ensure compliance with pertinent federal, state, and local laws and regulations.

Periodically, this book will be updated without notice as new products are introduced and additional information regarding these products become available. It is the responsibility of the upfitter to ensure they have the most up-to-date version.

NOTE

As an upfitter, you must always bear in mind that only the upfit work described in the BEG is permissible. All upfit work not described here is prohibited. If any upfit work not described here is necessary, consult with Upfitter Management Vans and appropriate support teams through the Upfitter Portal for Expert Upfitters

The latest copies of this BEG, 2D drawings, and model specifications may be obtained 24 hours/ day and 7 days/ week through the Upfitter Portal.

Other relevant information and guidelines that supplement the BEG are also available for download on the Upfitter Portal under "Technical Information", same location as the BEG.

1.1 Purpose of Body and Equipment Guideline

The BEG is divided into 10 interlinked chapters to help you find the information you require more quickly:

Chapter 1 Introduction (→ page 5)

Chapter 2 General (→ page 10)

Chapter 3 Planning of bodies (→ page 25)

Chapter 4 Technical limit values for planning (→ page 47)

Chapter 5 Damage prevention (→ page 54)

Chapter 6 Modifications to the basic vehicle (→ page 61)

Chapter 7 Design of bodies (→ page 91)

Chapter 8 Electrics/electronics (→ page 95)

Chapter 9 Calculations (→ page 126)

Chapter 10 Technical details (→ page 132)

Appendix:

Chapter Index (→ page 134)

- ❗ For more information see sub-chapter 2.2 Product and vehicle information for upfitters (→ page 12).

The index in PDF format is linked to help you find the information you require quickly.

Make absolutely sure that you observe the limit values specified in chapter 4 Technical limit values for planning (→ page 47) as planning must be based on these values.

The chapters entitled "Modifications to the basic vehicle", "Design of bodies" and "Electrics/electronics" are the main source of technical information contained in the BEG.

- ❗ To ensure the operational reliability and road safety of the overall vehicles, the information given in the BEG must be strictly followed.
- ❗ On account of the ongoing technical evolution of Mercedes-Benz van products, the upfitters are notified at points between the regular publication dates about the latest topics or contents/updates as part of a "BEG Addendums".
- ❗ The "BEG Addendums" are available for free access in the Mercedes-Benz Upfitter Portal (www.Upfitter-Portal.com) along with the BEG.

If you are using a printed version of the "BEG", the following should be noted: important revisions to BEG, such as updates will in future be published as "Addendums" in the Upfitter Portal.

On the publication in the Upfitter Portal, these revisions to the BEG become a component part of the current BEG or supersede the previous version of the BEG and must be complied with.

Illustrations and schematic drawings are examples only and serve to explain the texts and tables.

❗ NOTE

All graphics are for illustrative purposes only and they do not depict all the technical details faithfully.

You can obtain further information from any Mercedes-Benz Service Partner.

1.2 Conventions

The following conventions are used in the BEG:

⚠ DANGER

Warning notes draw attention to issues which will endanger the health or life of yourself or others.

▶ Action

⚠ WARNING

Warning notes draw attention to issues which could endanger the health or life of yourself or others.

▶ Action

! NOTE

This note draws your attention to possible damage to the vehicle and/or other objects.

▶ Action



ENVIRONMENTAL NOTE

An environmental note gives you tips on how to protect the environment.

▶ Action

i Useful notes or further information and information sources which could be helpful to you.

→ This symbol indicates where you can find further information about a topic.

▶ Action

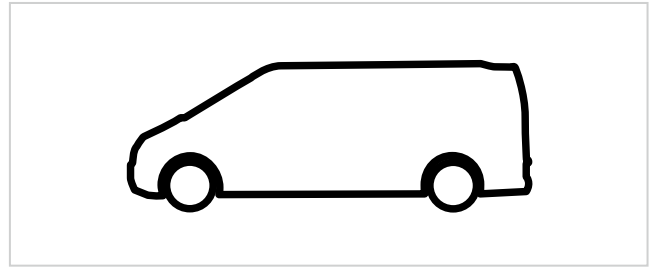

Basic vehicle

Under this symbol you will find information concerning the delivered basic vehicle (cargo and passenger vans).

1.3 Vehicle safety

WARNING

Before starting to install other make bodies or equipment, please read the relevant chapters of the BEG, the instructions and information from the equipment supplier and the detailed operator's manual for the base model vehicle. You could otherwise fail to recognize dangers which could result in injury to yourself or others.

Notes on vehicle safety

We recommend that you use parts, major assemblies, conversion parts or accessory parts which are suitable for the respective vehicle model and have been tested by Mercedes-Benz.

If parts, major assemblies, conversion parts or accessory parts are used that have not been recommended, it is the upfitter's sole responsibility to ensure the safety of the vehicle.

NOTE

Make absolutely sure that you comply with national and local registration regulations as well as DOT requirements as upfit work to the vehicle may change the vehicle type for registration purposes and may invalidate the operating permit. This applies in particular to:

- modifications which change the vehicle type approved in the general operating permit
- modifications which could endanger road users
- modifications which adversely affect exhaust emissions or noise levels

Vehicle modifications by the upfitter

Before starting upfit work, the upfitter must check whether:

- the vehicle is suitable for the planned body
- the vehicle model and equipment are suitable for the operating conditions intended for the body

The upfitter must inform the officially recognized approval authority or inspector of any modifications to the basic vehicle. The approval and inspection organizations will decide on compliance with legislation and regulations after any modifications made to the basic vehicle, and therefore on the registration requirements for the complete vehicle.

The upfitter must ensure that the vehicle meets the registration requirements with his modifications.

NOTE

National and local laws, directives and registration regulations must be complied with.

1.4 Operational safety

WARNING

Modifications to electronic components, their software or wiring can impair their functioning and/or the functioning of other networked components. Safety-relevant systems in particular may also be affected. Because of this, they may no longer function properly and/or compromise the operational safety of the vehicle.

There is a heightened risk of accident and injury! Never carry out any modifications to the wiring and electronic components or their software. Have all work on electrical and electronic equipment carried out at a qualified specialist workshop.

We recommend that you use an authorized Mercedes-Benz Service Center for this purpose.

Some of the safety systems only function when the engine is running. For this reason, do not switch off the engine when the vehicle is in motion.

1.5 Note on copyright

All the text, illustrations and data contained in these Body and Equipment Guideline are protected by copyright.

This also applies for the editions on CD-ROM, DVD or other media.

If you have any questions, please contact Upfitter Management Vans through the Upfitter Portal.

www.UpfitterPortal.com

2.1 Advice for upfitters

Technical advice on body compatibility

To obtain technical assistance or product/parts information ONLY as it pertains to upfitting and modifying Metris vans please contact the Upfitter Management Vans through the Upfitter Portal:

www.UpfitterPortal.com

To contact Upfitter Management Vans, create an inquiry through the Upfitter Portal inquiry center (please allow up to 5 business days for more complex inquiries).

Advanced support for ExpertUpfitter program members

ExpertUpfitters can enjoy a dedicated ExpertUpfitter Dashboard that is reached via a special login on the Upfitter Portal. From the dashboard, ExpertUpfitters can receive VIP Technical Support and have the ability to propose upfit solutions for review by Upfitter Management Vans. Proposed solutions will be considered based on scale and complexity and should fall outside of the contents described in this BEG.

For more information about the ExpertUpfitter Program, please visit: **www.UpfitterPortal.com/en-us/upfitters/program-overview**

For all other inquiries non-related to upfitting or modifying Sprinter, but pertaining to model availability, ordering/purchasing a van, service center capabilities and to get local support, please contact an authorized dealership authorized by Upfitter Management Vans.

The most current list of dealers can be found here:

Mercedes-Benz USA Dealers

www.mbvans.com

Mercedes-Benz Canada Dealers

www.mercedes-benz-vans.ca

Technical advice on the parameterizable special module (PSM/MPM)

For the Metris - BR 447 an advanced form of the familiar PSM (MPM) is available, also designated internally as the multifunction control unit (or multi-purpose module (MPM)), which can be ordered under the code ED5 (PSM/MPM).

In addition to the information on the parameterizable special module under Chapter 8.8 Parameterizable special module PSM (MPM) (→ page 119), the PSM/MPM Information page on the Upfitter Portal is available for more information. For additional questions, please create a new inquiry on the Upfitter Portal inquiry center.

2.1.1 Certificate of non-objection

Mercedes-Benz AG does not issue any body and/or equipment approvals for non-MB bodies. These directives only supply important information and technical specifications to upfitters explaining how to handle the product. Mercedes-Benz AG therefore recommends that all work on the basic vehicle and body is performed in compliance with the permissible gross mass and permissible axle load, as per the current Mercedes-Benz Body and Equipment Guideline applicable to the vehicle.

Mercedes-Benz AG issues certificates of non-objection voluntarily based on the following criteria:

Mercedes-Benz AG's assessment shall be based solely on the documents submitted by the upfitters carrying out the modifications. The assessment and certification shall only cover the expressly defined scopes and their basic compatibility with the designated chassis and its interfaces or, in the case of chassis modifications, the basic feasibility of the design for the designated chassis. The certificate of non-objection shall not refer to the overall design of the body, its functions or its intended application. The certificate of non-objection shall only be valid if design, production and assembly are performed by the upfitter carrying out the modifications in accordance with the state of the art and in compliance with the valid Body and Equipment Guideline of Mercedes-Benz AG - unless deviations from these directives are endorsed. Nevertheless, the certificate of non-objection does not release the upfitter carrying out the modifications from its product liability or its obligation to perform its own calculations, tests and trials in order to ensure that the overall vehicle produced by the company meets the required specifications for operational safety, road safety and handling characteristics.

2.1.2 Legal claims

- No legal claim can be made as to the issuance of a certificate of non-objection.
- Mercedes-Benz AG reserves the right to revoke any certificate of non-objection due to ongoing technical development and the knowledge gained from it, even if a similar certificate was issued in the past.
- The certificate of non-objection applies only for the specifically requested body and the specifically requested vehicle. For further vehicle modifications to the body or for bodies on a different vehicle a new certificate of non-objection is required in each case.
- The retroactive issue of a certificate of non-objection for vehicles already completed or delivered can be refused.
- The upfitter alone shall be responsible for compliance with the following requirements:
 - The functionality and compatibility with the basic vehicle of his body modifications
 - Operating and road safety
 - All body modifications and fitted parts

2.2 Product and vehicle information for upfitters

As an upfitter, you are also able to obtain detailed information on our products and systems in addition to the possibility of directly contacting the Upfitter Management Vans (→ page 10).

2.2.1 Upfitter Portal

General

The Upfitter Portal is the central communications platform between Upfitter Management Vans and you, our partners in the body manufacturing industry. The Upfitter Portal provides information and access to body-related topics for all model series of Mercedes-Benz trucks and vans. The portal can be accessed at the following address:

www.UpfitterPortal.com

Technical Information

In the **Technical Information** section of the portal, you can find the relevant technical data sheets, 2D chassis drawings, technical bulletins, and the Body and Equipment Guideline.

Design data and drawings

From the beginning of 2018, 3D standard data packages in STEP AP214 format will be available for ExpertUpfitters to download for the Metris in the Upfitter Portal.

2.2.2 Information for upfitters

Upfitters can find after-sales information at:

<https://xentry.daimler.com/>

<https://www.startekinfo.com/>

There you will find information on the following topics:

- Service/parts information
- Diagnosis
- SCN coding
- Special tools
- TIPS

2.2.3 Workshop Information System (WIS)

The Workshop Information System (WIS) is available under the following website:

<https://www.startekinfo.com/home>

For example, WIS contains:

- Basic data (dimensions, tightening torques)
- Function descriptions
- Wiring diagrams
- Repair instructions
- Maintenance sheets

 Further information can be obtained from your Mercedes-Benz Service Partner or the Customer Support.

2.2.4 XENTRY Kit

The diagnostic tool XENTRY Kit is available to you for the XENTRY system as a component of "Service & Parts net." under the heading "Diagnosis". The XENTRY Kit diagnostic tool was developed by Mercedes-Benz to facilitate vehicle diagnosis. The XENTRY Kit can be used to read out fault entries from the vehicle and diagnose them. It is also possible to change the parameters of control units, e.g. in the parameterizable special module (PSM/MPM).

Fault entries which occurred during the mounting of the body can also be erased.

In addition, XENTRY Kit can also be used to update control units using SCN coding. For example, online SCN coding must be used on the Metris - BR 447 to update the data (coding) for the instrument cluster.

It is possible to connect the XENTRY Kit to the central server of Mercedes-Benz during SCN coding using a LAN or WLAN connection. The relevant SCN coding is requested online and is used to uniquely identify the control unit variants installed in the vehicle. Furthermore, it is possible to update the control units or to commission them during replacement. The appropriate software is determined online and installed using the suitable data storage medium.

-  Further information on the use of SCN coding and the updating of control units, as well as information on the XENTRY product world, can also be found in Service & Parts net.

XENTRY Kit can be purchased or leased by upfitters.

All XENTRY Diagnosis Systems have 3.5 year (42 months) warranty. Should the hardware/software issue arise during the warranty period there is a Star Diagnosis Support Desk that can be reached by calling 201-505-4630 or by email at mbdiagnosis@mbusa.com.

The help desk is open Monday - Friday from 8 AM to 8 PM (EST).

For further questions, please contact support.xsf@daimler.com.

2.2.5 Regulatory overview

The U.S and Canadian governments have established emission standards and motor vehicle safety standards for new engines and/or new vehicles and equipment under the provisions of the Clean Air Act, the Noise Control Act and the National Traffic and Motor Vehicle Safety Act in the U.S., and the Canadian Motor Vehicle Safety Act in Canada (“Acts”). The acts govern original equipment manufacturers of the Mercedes-Benz Metris vans, dealers, upfitters and others engaged in the manufacturing and marketing of new motor vehicles and equipment.

Part 568 of the Title 49 Code of Federal regulations (CFR) specifies detailed regulatory requirements for vehicles manufactured in two or more stages, including final stage manufacturers. This document is intended to fulfill a part of Mercedes-Benz AG’s obligations as the original equipment manufacturer or as an incomplete vehicle manufacturer. Section 2.2.6 Emissions and safety information (→ page 15) identifies regulatory requirements to assist Intermediate and final stage manufacturers in determining their obligations to conform to these standards.

Completed Metris “As Delivered” is certified to comply with the aforementioned applicable standards. Compliance labels affixed to Metris and engines provide the status of initial compliance at the date of manufactured by Mercedes-Benz AG.

Upfitters and dealers who make any modifications that may affect the final certification of the engine, vehicle, or equipment assume the sole responsibility for the vehicle.

Upfitters should consult with their legal counsel concerning the final certification status of the vehicle.

Furthermore, it is the upfitter’s responsibility to ensure that such modifications do not affect the safety of the vehicle. Contact the Environment Protection Agency (U.S. EPA) and the California Air Resources Board (CARB) concerning the applicable U.S. and California exhaust emissions and noise standards, and the National Highway Traffic Safety Administration (NHTSA) concerning the applicable U.S. vehicle safety standards. For Canadian standards, contact Environment Canada and Transport Canada respectively.

Upon completion of the modifying the vehicle, the upfitter is required by law (Title 49 of the Code of Federal Regulations S567.7 in the United States, the Clean Air

Act section 203(a), and under provisions of EPA CFR Part 86) to certify that the modified vehicle continues to comply with all applicable U.S. and Canada motor vehicle safety standards and regulations. In addition, the modified vehicle must continue to comply with all applicable U.S., Canada, and/or California Emissions regulations. In the United States, sale of a non-complying new vehicle is illegal and is punishable by a fine of up \$25,000 (federal) and \$5,000 (California) per vehicle for emissions non-compliance, \$1,000 per vehicle for safety non-compliance, plus a recall and other sanctions.

Upfitters are responsible for certifying the altered vehicle pursuant to Title 49 of the Code of Federal Regulations S567.7 and S568.8 in the United States or to Section 9 of the Canadian Motor Vehicle safety Regulations in Canada.

Mercedes-Benz AG and Upfitter Management Vans make no representations with regard to conformity of the altered vehicle to any other federal or Canada motor vehicle safety standards or regulations that may be affected by the vehicle alteration; it is the responsibility of the upfitter to certify that the vehicle conforms to any other standards affected by the vehicle alteration.

2.2.6 Emissions and safety information

A complete Metris van “As Delivered” or an incomplete vehicle, delivered by MBUSA, MBCAN and MBV to dealers or upfitters is certified for by Mercedes-Benz AG for compliance with the U.S. and Canadian emissions and safety standards at the time of manufacture. If this vehicle is altered, after delivery by MBUSA, MBCAN and MBV, upfitters and/or dealers assume the regulatory responsibility for certification.

This section provides general information concerning applicable emissions and safety standards at the time of the vehicle manufacture. This section is written to assist upfitters in understanding the U.S. EPA and the CARB exhaust emission and noise standards, Federal Motor Vehicle Safety Standards (FMVSS) and Canadian Motor Vehicle Safety Standards (CMVSS). Upfitter Management Vans neither approves nor recommends any modifications or additions to the Metris vehicle, which may cause noncompliance with any EPA or FMVSS or CMVSS standards, or render the vehicle unsafe.

Questions concerning the content of this section can be directed to MBUSA, MBCAN or MBV designee through the Upfitter Portal:

Contact via website

www.UpfitterPortal.com

Engine calibrations such as fuel output settings, injection timings, emission control device calibration, and location, charge air and cooling system calibration and locations are prohibited from any alterations from the certified configurations.

Provisions of the Clean Air Act also prohibit any persons, including but not limited to, dealers or upfitters to remove or render inoperative any devices or elements of design installed in a motor vehicle engine in compliance with the regulations.

2.2.7 Vehicle safety standards information

In the U.S. National Traffic and Motor Vehicle Safety Act of 1966 and NHTSA’s FMVSS regulations and in Canada, Motor Safety Act of 1993 and Transport Canada’s (TC) CMVSS identify certain requirements and certification responsibilities for the various stages of vehicle manufacturing.

Therefore, upfitters and dealers need to review all regulatory requirements carefully to ensure compliance with applicable standards.

Please consult with an attorney to ensure compliance with applicable laws or standards.

All vehicles as manufactured by Mercedes-Benz AG meet all safety and emissions standards as set forth by the National Highway Traffic Safety Administration (NHTSA) and the Environmental Protection Agency (EPA). If any modifications or alterations are made to the vehicle that takes the vehicle out of compliance with Federal and local regulations, it is the responsibility of the vehicle alterer, intermediate manufacturer, or final stage manufacturer to ensure the vehicle meets all emissions and FMVSS/CMVSS standards.

For manufacturers who are defined as alterers, please visit www.nhtsa.gov for regulatory direction.

For intermediate or final stage manufacturers please visit www.nhtsa.gov as well as reviewing the Incomplete Vehicle Document (IVD) that is included in each incomplete vehicle as manufactured by Mercedes-Benz AG. At no time the BEG should ever be used as a regulatory source for certification. Each upfitter or modifier is advised to have his or her own regulatory department or consultant.

2.2.8 Exhaust emission control information

The Metris engine Mercedes-Benz M274 is certified with the U.S. EPA, and the Environment Canada and CARB. Provisions of the EPA regulations require that the emission related components functions in-use over the prescribed full useful life period as certified, i.e., 5 years or 100,000 miles (short term emission control system) and 7 years or 70,000 miles (long term emission control system), whichever occurs first. To be certain that these components function properly, the end users are required to use appropriate fuels and lubricants and maintain these components properly in accordance with the Operator's Manual and Service Booklet.

Additionally, there is a requirement for applicable noise control packages that were tested at over 100% reduction in noise levels below the aforementioned noise standards. Final stage manufacturers should consult with their attorney concerning the compliance of their vehicles with appropriate regulations and laws once they have been altered or modified. The law and regulations prohibit tampering with noise control devices or components.

Specifically, the removal or rendering inoperative of any devices or elements of design incorporated into any new vehicle for the purpose of noise control is not permitted. Such devices or elements are identified as noise emission related components, such as engine calibrations including governor settings, exhaust system components, air induction system components, radiator, shield, fan/drive, noise shields or acoustical absorptive material, etc.

The regulations also require maintenance of the noise control performance in use, to comply with the U.S. EPA 40 CFR Part 202, or DOT 49 CFR part 325, Exterior Drive-By Noise Emission Standards for Interstate Motor Carrier.

2.3 Product safety and product liability

2.3.1 Product safety

Both vehicle manufacturers and upfitters must always ensure that the products they manufacture are safe when they are brought into circulation and do not present any danger to persons or property. Otherwise there may be consequences under civil, criminal or administrative law. Every manufacturer is always liable for the product that it has manufactured.

Furthermore, the upfitter must guarantee compliance with standards relating to functional safety (preferably ISO 26262).

2.3.2 Product liability

The upfitter bears responsibility for the operational and road safety of the body mounting work performed by the upfitter, and in particular for:

- testing and maintaining the operating and driving safety of the overall vehicle after the body is mounted (the body must not have a negative effect on the driving, braking or steering characteristics of the vehicle)
- the effects of body mounting work on the chassis
- consequential damage arising from upfit work
- consequential damage resulting from retrofitted electrical and electronic systems
- maintaining the functional reliability and unobstructed movement of all moving parts of the chassis (e.g. axles, springs, propeller shafts, steering, gear-shift linkage, etc.) after the body mounting work is complete; even in the case of diagonal torsion of the vehicle

Work carried out or modifications on the chassis or body must be entered in the maintenance booklet, section "Confirmations of the upfitter".

2.3.3 Safety-relevant features

Components and systems are safety-relevant when their fault or failure could result in an immediate danger to the life and limb of road users.

Upfitter Management Vans recommends that an assessment of the safety relevance of the components or functions be carried out for the following work:

- Chassis modifications
- Vehicle installations
- The interface between vehicle and body (mechanical components, electrics/electronics, power take-offs, hydraulic components, pneumatics)

A component or function must be classified as safety relevant if one of the following ten safety functions in particular is affected:

- Occupant protection in accidents
- Avoiding momentary loss of road view
- Avoiding steering failure
- Avoiding loss or partial failure of braking function
- Avoiding failure of driving function
- Avoiding uncontrolled drive
- Avoiding sudden failure of drive force
- Avoiding leakage of operating fluids/risk of fire
- Avoiding loosening of cargo/trailers/parts/bodies/semitrailers
- Avoiding injury while driving and during alternative operation of the vehicle

The following customer-related influences must be considered when evaluating safety relevance:

- Extreme operating conditions
- Wear and tear
- Ambient conditions

Documentation

If safety relevance is identified according to the ten safety aspects, these aspects are to be appropriately marked as safety-relevant in paper and data records and the associated functions and features documented as well as the measures taken to avoid the dangers.

2.4 Guarantee of traceability

There is a possibility that body-related hazards may only be detected after the vehicle is delivered, making retroactive market measures necessary (customer information bulletins, warnings, recalls). To ensure that these measures can be implemented as efficiently as possible, it must be possible to trace the product after delivery.

We strongly recommend that upfitters file the serial number/identification number of their body together with the vehicle identification number of the basic vehicle in their databases for this purpose and to allow them to use the NHTSA or Transport Canada to determine the affected vehicle owners. On this note, the storage of customer addresses is also recommended as is giving subsequent owners the possibility to register their details.

2.5 Trademarks

2.5.1 The Mercedes-Benz brand in interaction with external upfitters

In terms of the relationship between Mercedes-Benz and upfitters, it is not just product safety and product liability which are of particularly high importance. The usage of the brand is also very important.

The aim of these guidelines is to explain the brand-related interests of Mercedes-Benz for Metris - BR 447 to upfitters.

The individual provisions of the guidelines do not release upfitters from their liability for aftermarket modifications to Mercedes-Benz vehicles.

2.5.2 The function of a brand

Every company which wishes to operate a successful brand must ensure that the characteristics of the brand are consistently protected. This also applies to the brands of Mercedes-Benz AG and Upfitter Management Vans.

The brand indicates the origin of a product and allows the product to be recognized and remembered. The brand acts as a guarantee for the quality of a product, embodying its characteristic values and identity.

2.5.3 Trademark protection

The trademark protection laws give Mercedes-Benz AG and Upfitter Management Vans the exclusive right to use its brands.

In particular, this applies to the use of Mercedes-Benz trademarks on vehicles and vehicle parts/accessories (e.g. rims) and in communication of the brand name.

2.5.4 Trademark rights

The "Mercedes star", the "Mercedes badge" and the "Mercedes-Benz" wordmark/logo are registered trademarks of Mercedes-Benz AG.



Mercedes-Benz

METRIS

2.5.5 Advice on applying Mercedes-Benz trademarks to vans

If you have any questions about applying Mercedes-Benz trademarks to Mercedes-Benz vans, the Upfitter Management Vans will be pleased to assist you. Please contact Upfitter Management Vans via the Upfitter Portal:

www.UpfitterPortal.com.

2.5.6 Use of Mercedes-Benz trademarks

Principle

Only Mercedes-Benz trademarks may be applied to completely unchanged Mercedes-Benz vehicles.

Modification of the Mercedes-Benz trademarks on vehicles of the Mercedes-Benz brand is not permissible.

The application of Mercedes-Benz trademarks to vehicles and parts other than those of the Mercedes-Benz brand is not permissible.

Mercedes-Benz trademarks on vehicles with technical modifications

When vehicles are modified in accordance with the Body and Equipment Guideline, the Mercedes-Benz trademarks may be left on the vehicles unchanged.

Extensive vehicle modifications significantly change the original condition of the vehicle e.g. through modifications to the suspension, body structure, engine, brake system and on-board electronics. These modifications are generally not covered by the Body and Equipment Guideline. This can result in deterioration of the overall vehicle with associated risks which Mercedes-Benz is not liable for according to product liability and product safety legislation.

For extensive vehicle modifications, an evaluation with the responsible department is necessary. As part of the ExpertUpfitter program, please refer to the Upfitter Portal, www.UpfitterPortal.com.

If the vehicle does not meet the requirements of Mercedes-Benz, Upfitter Management Vans reserves the right to demand removal of its trademarks.

2.5.7 Brand separation/identity

Principle

Mercedes-Benz model series have specific characteristics and values as well as a brand-specific design. The modifications should be in the style of the Mercedes-Benz design characteristics.

Separating the Mercedes-Benz trademarks from the upfitter trademarks ensures that a distinction can be made between the brands. This applies, in particular, to product origin and the resulting responsibilities.

Upfitter Management Vans reserves the right to demand immediate removal of the Mercedes-Benz trademarks if the vehicle fails to comply with the requirements of Mercedes-Benz.

Trademarks on the front of the vehicle

Use of the Mercedes star

- On vehicles with genuine Mercedes-Benz cabs, the Mercedes star must be retained in the as-delivered state.
- On vehicles with a cab designed separately by the upfitter, the Mercedes star may be applied to the front-end assembly in the center in order to identify the chassis. If the upfitter brand is also applied, it must be applied at an appropriate distance from the Mercedes star.

Use of the Mercedes badge

- The Mercedes badge signifies an original Mercedes-Benz design. It may only be retained on vehicles with a genuine Mercedes-Benz cab.
- The use of the Mercedes badge is not permissible on vehicles with a cab separately designed by the upfitter.

Model series and vehicle model designation at front of vehicle

The Metris - BR 447 does not have any model series designations at the front of the vehicle. Model series designations may not therefore be applied to vehicles modified by upfitters.

Trademarks at the rear area of the vehicle

Use of the Mercedes star

When the Mercedes star is applied to the rear area of vehicles whose appearance has been extensively changed by a body or other modifications, Upfitter Management Vans reserves the right to demand immediate removal of the Mercedes star. It is recommended that the upfitter should discuss the matter with Upfitter Management Vans before application.

Upfitter trademarks in combination with Mercedes-Benz trademarks

Upfitters that attach their trademarks to their body must ensure that they are located at a suitable distance away from Mercedes-Benz trademarks or badges.

2.5.8 Trademark communication

Use of Mercedes-Benz trademarks in communication

The use of Mercedes-Benz trademarks in communication instruments such as, e.g. brochures, flyers, advertisements or pennants will be governed in future by the style guide for the upfitters of Mercedes-Benz vans.

The upfitter must be clearly identifiable in all its communication media and channels as the originator of the communication.

When displaying modified vehicles that comply with the Mercedes-Benz guidelines and that bear our trademarks, care should be taken to ensure that any modification to the vehicle or the vehicle body made by the upfitter is visible in the display. Only the obvious accentuation of Mercedes-Benz trademarks without any visible attachment, extension or conversion is not permissible.

The use of Mercedes-Benz trademarks in corporate design, i.e. on letterhead paper, business cards, on work clothes, etc. and in the showrooms, offices and workshops is not permitted.

2.6 Accident prevention

The body and attached or installed equipment must comply with all applicable laws and regulations, and with health and safety and accident prevention regulations, safety regulations and information sheets issued by accident insurers.

All technical means shall be used to avoid operating conditions that may be unsafe or liable to cause an accident.

National and local laws, directives and registration regulations must be complied with.

The upfitter shall be responsible for compliance with these laws and regulations.

2.7 Reprocessing of components - recycling



ENVIRONMENTAL NOTE

When planning bodies or equipment, the following principles for environmentally compatible design and material selection is recommended to be taken into account.

Upfitters shall ensure that attachments and bodies (or conversions) comply with current environmental legislation and applicable regulations.

The installation documentation for the conversions shall be kept by the vehicle owner and, if the vehicle is to be scrapped, handed over to the dismantling company concerned at the time of vehicle handover. This is intended to ensure that even converted vehicles are processed in an environmentally responsible manner.

Materials with risk potential such as halogen additions, heavy metals, asbestos, CFC and CHC, are to be avoided.

- It is preferable to use materials which permit recycling and closed material cycles.
- Materials and production processes that generate only low quantities of easily recyclable waste during production must be selected.
- Plastics are to be used only where they provide advantages in terms of cost, function or weight.
- In the case of plastics, and composite materials in particular, only compatible substances within one material family are to be used.
- For components which are relevant to recycling, the number of different types of plastics used must be kept to a minimum.
- It must be assessed whether a component can be made from recycled material or with recycled elements.
- It must be ensured that components can be dismantled easily for recycling, e.g. by snap connections, predetermined breaking points, easy accessibility, or by using standard tools.
- It must be ensured that service fluids can be removed simply and in an environmentally responsible manner by means of drain screws etc.
- Wherever possible, components should not be painted or coated; pigmented plastic parts are to be used instead.
- Components in areas at risk from accidents must be designed in such a way that they are damage-tolerant, repairable and easy to replace.
- All plastic parts are to be marked in accordance with the VDA Materials Leaflet 260 ("Components of motor vehicles; identification of materials"), e.g. "PP - GF30R".

2.8 Quality system

World-wide competition, increased quality standards demanded by the customer from the van as a whole, national and international product liability laws, new organizational forms and rising cost pressures make efficient quality assurance systems a necessity in all sectors of the automotive industry.

The requirements for a quality management system of this kind are described in DIN EN ISO 9001.

A working group of the VDA (Association of the German Automotive Industry) has produced the guideline "Quality management in the automotive industry - Minimum requirements for a management system for trailer and upfitters - System description and assessment" for German upfitters, which is based on DIN EN ISO 9000 ff. Published as VDA Volume 8 [VDA 8] (including CD-ROM), order no. A 13DA00080.

For the reasons quoted above, Upfitter Management Vans urgently advises all upfitters to set up and maintain a quality management system with the following minimum requirements:

- To define responsibilities and authorities including organizational planning
- To describe processes and procedures
- To appoint a manager responsible for quality
- To carry out contractual inspections and buildability checks
- To carry out product tests in accordance with the specified procedure stated in the test instructions
- To regulate the handling of faulty products
- To document and archive test results
- To ensure that all employees have currently valid proof of the qualification required
- To systematically monitor the test equipment
- To systematically identify materials and parts
- To carry out quality assurance measures at the suppliers
- To ensure that the instructions for processes, work and inspections are up-to-date and available in all departments and at all workplaces

General

The relevant opening conditions of the subsequent complete vehicle are crucial to the selection of a suitable basic vehicle when planning work on the vehicle body.

Observe the following points:

- Customized design of vehicle
- Body variant
- Standard and special equipment

For better orientation when planning, the identification plate, the model designation and the vehicle identification number (VIN) must be used; see Chapter 3.4 Vehicle identification data (→ page 33).

More detailed information on the vehicle and body variants on offer is available in Chapter 3.1.2 Model overview (→ page 28) or Chapter 2.2.1 Upfitter Portal (→ page 12).

! NOTE

When planning bodies, in addition to a user-friendly and maintenance-friendly design, the careful choice of materials and the associated anti-corrosion protection measures are of great importance (→ page 57).

3.1 Selecting the basic vehicle

In order to ensure safe operation of the vehicle, it is essential to choose the basic vehicle carefully in accordance with the intended use.

Here, the following points should be taken into account in the planning phase and adapted to the respective field of application:

- Wheelbase
- Engine/transmission
- Final drive ratio
- Permissible gross mass and axle loads
- Position of the center of gravity
- Standard and special equipment
- Compatibility of the assistance systems

! NOTE

When planning bodies, in addition to a user-friendly and maintenance-friendly design, the careful choice of materials and the associated anti-corrosion protection measures are of great importance (→ page 57).

! NOTE

Before carrying out body modifications, the delivered vehicle must be submitted to a check to verify whether it fulfills the necessary requirements.

- ① On the Mercedes-Benz homepage, you can assemble vehicles in the Configurator and view the available items of special equipment:

www.mbvans.com

- ① For more information on the chassis and body variants on offer, see Chapter 3.1.2 Model overview (→ page 28) or contact the department responsible (→ page 10).

Further information can be found in the Technical Information bulletins in the Upfitter Portal (→ page 12).

3.1.1 Vehicle and model designation

For information on the position of the identification plates, see Chapter 3.4 Vehicle identification data (→ page 33).

Information about the feasibility and registration requirements of the vehicle can be obtained via the relevant contact person at “Advice for upfitters” (→ page 10).

The Body and Equipment Guideline is valid for the following vehicle model designations of the Metris - BM 447:

Versions and model designations

Model version	Wheelbase	Model designation by permissible gross mass	
	[mm/in]	2900 kg/ 6393 lbs (XA9)	3100 kg/ 6,834 lbs (XA8)
Cargo van	3200 / 126"	447.603	447.603
	3430 / 135"	447.605	447.605
Passenger van	3200 / 126"	447.703	447.703

Body lengths

Metris	Wheelbase	Overhang at front	Overhang at rear	Overall length
	[mm/in]	[mm/in]	[mm/in]	[mm/in]
Short (A2)	3200 / 126"	895 / 35.2"	1045 / 41.1"	5140 / 202.4"
Long (A3)	3430 / 135"	895 / 35.2"	1045 / 41.1"	5370 / 211.4"

Further dimensional data can be found in the "2D chassis drawings (offer drawings)" in the Upfitter Portal (→ page 12). National regulations must be complied with.

3 Planning of bodies

3.1.2 Model overview

Metris Cargo van

Weight variant Code	Short (A2), BM 447.603, 126" WB	Long (A3), BM 447.605, 135" WB
	Engine: MM1	Engine: MM1
2.9t (6393 lbs) Code XA9		
	Engine: MM1	Engine: MM1
3.1t (6834 lbs) Code XA8"		

The weight variant is controlled not by the model designation, but by a code.

Vehicle dimensions of Metris panel van

Body length	Wheelbase	Overhang at front	Overhang at rear	Vehicle length	Vehicle width	Vehicle height
	[mm / in]	[mm / in]	[mm / in]	[mm / in]	[mm / in]	[mm / in]
Short (A2)	3200 / 126"	895 / 35.2"	1045 / 41.1"	5140 / 202.4"	1928 / 75.9"	1910 / 75.2"
Long (A3)	3430 / 135"	895 / 35.2"	1045 / 41.1"	5370 / 211.4"	1928 / 75.9"	1910 / 75.2"

Metris Passenger van

Weight variant Code	A2 (short), BM 447.703, 126" WB
	Engine: MM1
2.9t (6393 lbs) Code XA9	
	Engine: MM1
3.1t (6834 lbs) Code XA8	

The weight variant is controlled not by the model designation, but by a code.

Vehicle dimensions of Metris Passenger van

Body length	Wheelbase	Overhang at front	Overhang at rear	Vehicle length	Vehicle width	Vehicle height
	[mm / in]	[mm / in]	[mm / in]	[mm / in]	[mm / in]	[mm / in]
Short (A2)	3200 / 126"	895 / 35.2"	1045 / 41.1"	5140 / 202.4"	1928 / 75.9"	1910 / 74.4"

3.2 Vehicle modifications

Before starting any vehicle modifications, the upfitter must check whether:

- the vehicle is suitable for the planned body
- the vehicle model and equipment are suitable for the operating conditions intended for the body.

You can plan bodies by requesting the department responsible to send you 2D chassis drawings (offer drawings), product information and technical data or you can retrieve this information from the communications system (→ page 12).

Furthermore, you should note the special equipment that is available from the factory (→ page 44).

As supplied ex-factory, all vehicles comply with EU Directives and national regulations (except for some vehicles for non-European countries).

The vehicles must still comply with EC regulations and national regulations after modifications have been carried out.

! NOTE

Adequate clearances must be maintained in order to ensure the function and operational safety of major assemblies.

⚠ WARNING

Any modifications to the steering and the brake system may result in these systems malfunctioning and ultimately failing. This could cause the driver to lose control of the vehicle. There is a risk of accident, personal injuries, and death associated with such tampering and unauthorized installations!

Do not carry out any modifications to the steering or brake system.

- i** The team “Technical advice on body compatibility”(→ page 10) is available to answer any questions you may have.

! NOTE

On no account should modifications be made to the noise encapsulation.

Vehicle approval

The upfitter must inform the officially recognized approval authority or inspector of any modifications to the basic vehicle. The approval and inspection organizations will decide on compliance with legislation and regulations after any modifications made to the basic vehicle, and therefore on the registration requirements for the complete vehicle.

! NOTE

National laws, directives and registration regulations must be complied with.

3.3 Dimensions and weights

On no account should modifications be made to the vehicle width, vehicle height or vehicle length if they exceed the limit values specified in the current version of the Body and Equipment Guideline.

Dimensions and weights are to be found in the 2D chassis drawings (offer drawings) and technical data in the Mercedes-Benz Upfitter Portal (→ page 12) and in the Technical Limit Values (→ page 47). These refer to vehicles equipped as standard - special equipment is not taken into account.

Weight tolerances of up to +5% in production is recommended to be taken into consideration.

The permissible axle loads and the maximum permissible gross mass must not be exceeded. For information on axle loads and maximum permissible gross mass, see "Advice for upfitters" (→ page 10). Here you will also find information about weight modifications.

- ▶ Before starting any upfit work, the actual vehicle curb weight and the corresponding axle loads at curb weight must be determined by weighing (see notes on weighing under Chapter 9.1.1 Determination of the center of gravity in the x-direction (→ page 126)), or by means of the vehicle identification number with the aid of the curb weight of your vehicle ex factory and its load distribution from your Mercedes-Benz partner.
- ▶ Following the completion of all the upfit work, repeat the measurement of actual vehicle curb weight (Chapter 9.1.1 Determination of the center of gravity in the x-direction (→ page 126)). The corresponding axle loads are likewise to be determined by weighing. The three variables of vehicle curb weight in the completed state, the front axle load and rear axle load in the completed state, must be documented again.
- ▶ In the case of a permanent axle load increase of 250 kg/ 551.2 lbs or more at the front axle on completion of all upfit work compared to the actual base model vehicle delivered to the upfitter (curb weight in standard configuration), the suspension must be measured and the correct toe and camber values must be set at the front axle.

WARNING

The vehicle's tire load capacity must not be exceeded by overloading the vehicle beyond its specified gross vehicle mass. The tires could otherwise overheat and suffer damage. This could cause the driver to lose control of the vehicle. There is a risk of accident, personal injuries, and death!

The braking distance may increase considerably when the vehicle is overloaded.

Information on the permissible masses is available on the identification plate in the vehicle (→ page 33).

These values can be obtained from your Mercedes-Benz Service Partner or directly from the WIS documents about wheel alignment. Information on the Mercedes-Benz Workshop Information System (WIS) can be found under Chapter 2.2.3 Workshop Information System (WIS) (→ page 12).

The information on the vehicle curb weight and corresponding axle loads before and after body mounting work, "Checking wheel alignment" in Chapter 3.9.3 Work before releasing the modified vehicle (→ page 42), Chapter 3.10 Special equipment (→ page 44), and Chapter 6.1.1 General information on the suspension (→ page 61) must be implemented.

⚠ WARNING

If the permissible axle loads are exceeded, the ESP® system may not function correctly on vehicles which are equipped with this feature. This could cause the driver to lose control of the vehicle. There is a risk of accident, personal injuries, and death!

Make sure that you do not exceed the permissible axle loads.

Information about changes in weight is available from your contact person (→ page 10).

! NOTE

All bodies must comply with the individual axle loads and the permissible gross mass.

Following vehicle modifications which can result in changes to the longitudinal and lateral inclination (e.g. the installation of heavy parts), the sensor cluster must be recalibrated in order to ensure that the ESP® is functioning correctly.

Mercedes-Benz AG recommends that you have this work performed at a qualified specialist workshop.

Further information on the operating principle of the ESP® is available in Chapter 8.7.1 Electronic Stability Program (ESP®) (→ page 111).

The permitted number of vehicle occupants and a sufficient margin for the payload must also be taken into account.

Take the weight of special equipment into consideration when making calculations.

Local and national regulations and directives must be observed.

3 Planning of bodies

3.3.1 Weight limits

The diagram below provides an overview of the weight limits that must be considered when upfitting Metris. This chapter serves as a guide for upfitters when modifying their vehicles and cannot serve as a replacement for reviewing the latest version of federal and local regulations on weight limitations. It is the upfitter's responsibility to ensure compliance with all federal and local regulations on weight limitations.

A = Base Curb Weight (BCW). BCW is the sum of the Metris vehicle weight and liquids necessary for vehicle operation at full capacity (e.g. fuel). The weight of the vehicle is variable and depends on the variant of the Metris and the option codes included in the specific vehicle. Liquids that are not necessary for vehicle operation should not be included.

B = Unloaded Vehicle Weight (UVW). UVW is the sum of the BCW value and the weight of permanently installed equipment added by the upfitter. Liquids that are not necessary for vehicle operation as well as any accessories should not be included. The maximum weight limit of UVW of 5,024 lbs. (2279 kg) for both XA9 and XA8 weight variants should not be exceeded.

C = Gross Vehicle Weight Rating (GVWR). GVWR is the sum of UVW value and the driver and passenger(s) weights as well as weights of the added cargo and/or luggage. The maximum weight limit of GVWR of 6,393 lbs (2900 kg) for XA9 variant or 6,834 lbs (3100 kg) for XA8 variant) should not be exceeded.

D = Gross Combination Weight Rating (GCWR). GCWR is the sum of GVWR value and the weight of any attached trailer and the cargo in the trailer. The maximum weight limit of GCWR of 111,391 lbs (5167 kg) for XA9 variant or 11,684 lbs (5300 kg) for XA8 variant should not be exceeded.

Payload before the upfit is payload of the vehicle without any upfit modifications and is calculated by subtracting the BCW from the GVWR. The payload value is provided on the tire label located on the B-pillar driver side door.

Payload after the upfit includes the weight of permanently installed equipment added by the upfitter and is calculated by subtracting the weight of the vehicle after the upfit from the GVWR. The label with payload (tire label on the B-pillar driver side door) provided by Mercedes-Benz will need to be updated by the upfitter with the payload after upfit value.

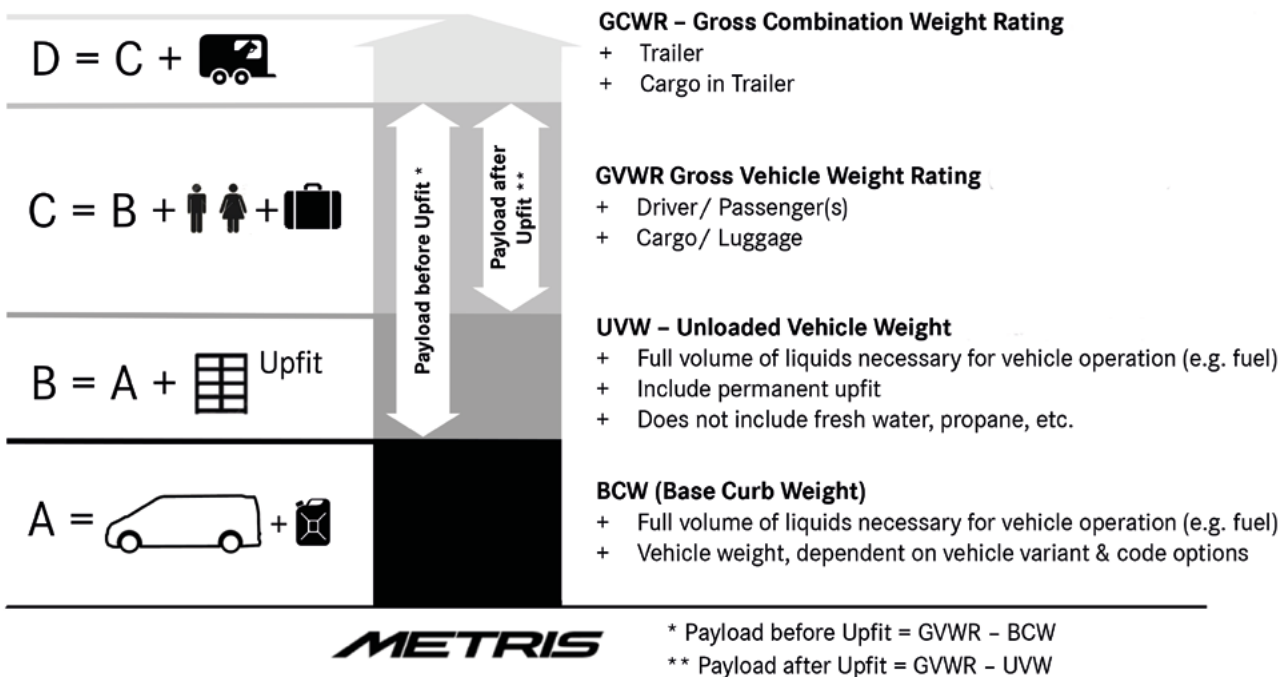

3.4 Vehicle identification data

! NOTE
 The vehicle identification number (VIN) and the vehicle identification plate may neither be changed nor fitted to a different point on the vehicle.

The identification plate with the vehicle identification number is inside the door frame on the left side.

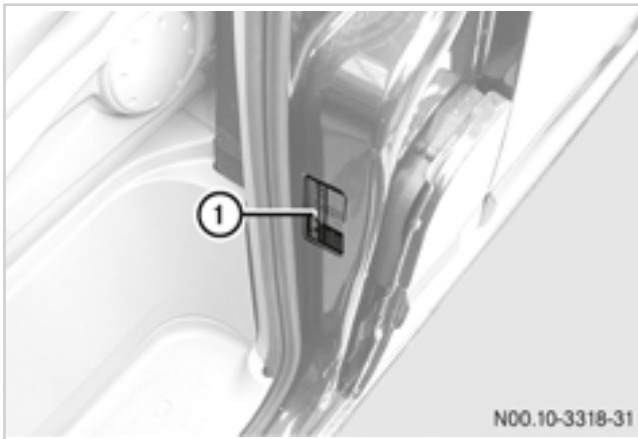

1 Vehicle identification plate on B-pillar on left side

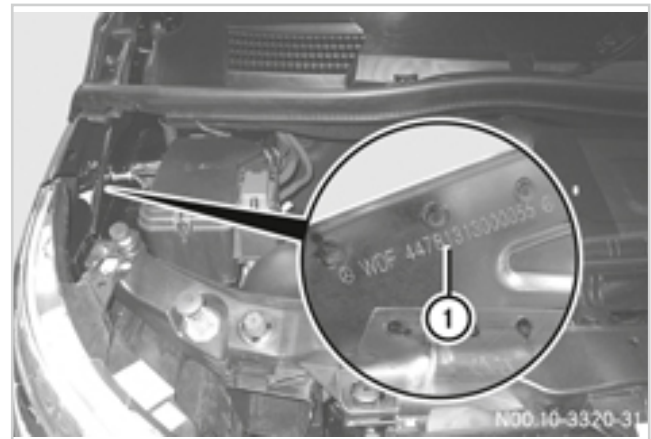

VIN in engine compartment

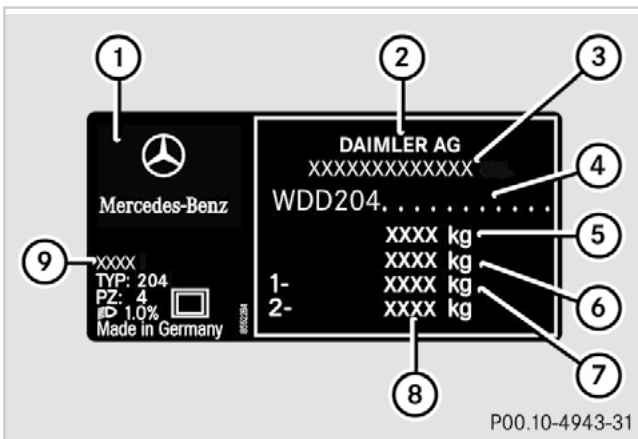

Example of an identification plate of a vehicle with trailer hitch

- 1 Vehicle identification plate
- 2 Vehicle manufacturer (Mercedes-Benz AG)
- 3 EC operating permit number (only for certain countries)
- 4 VIN
- 5 Permissible gross mass (kg)
- 6 Permissible gross combination mass (kg) (only for certain countries)
- 7 Permissible front axle load (kg)
- 8 Permissible rear axle load (kg)
- 9 Paint code

3.4.1 QR code rescue sticker



Attachment (example) of QR code rescue sticker on left B-pillar (schematic diagram)

All vehicles are supplied with a QR code rescue sticker from the production plant at Vitoria. The rescue stickers in the Metris are affixed to the left and right B-pillars.

When the QR code on the sticker is scanned using a smartphone or tablet and there is an existing internet connection, the current rescue card for the vehicle is displayed. The rescue card is displayed in the language set on the mobile terminal device. If the national language is not available, the system resorts to the English version. Rescue crews can thus immediately see where airbags, battery, fuel tanks, electric lines, pressure cylinders and other components critical for the rescue are located, enabling them for example to use rescue shears with low risk.

If the rescue stickers affixed at the factory become unusable in the course of your body mounting work, you can obtain replacements for the vehicle in question through your Mercedes-Benz Service Partner and install them on the B-pillars. Alternatively, the same partner can provide you with a printed version of the vehicle's rescue card for filing in the vehicle document folder.

i Further information on the rescue sticker is available in the Upfitter Portal (→ page 12).

www.UpfitterPortal.com

3.5 Vehicle stability

For the review of the vehicle with the body mounted, calculated proof of the height of the center of gravity of the laden vehicle must be provided to the Upfitter Management Vans for ExpertUpfitters.

See Chapter 4 Technical limit values for planning (→ page 47) for the permissible CoG heights.

Upfitter Management Vans will make no statements concerning

- driving characteristics
- braking characteristics
- steering characteristics
- ESP® control response

This applies to bodies intended for operation with loads with unfavorable centers of gravity (e.g. loads at the rear end, high loads and side loads), as these aspects are primarily influenced by upfit work and can therefore be assessed exclusively by the upfitter.

⚠ WARNING

If an attachment, the body, mounted equipment or modifications cause an extreme displacement of the center of gravity on a vehicle equipped with ESP®, it may be necessary to deactivate ESP® if this is possible while still observing and complying with all national registration requirements.

If ESP® has been deactivated, the driver will then have to adapt their style of driving accordingly (reducing cornering speed, avoiding sudden steering wheel movements, etc.). When driving dynamics become critical, the vehicle behaves like a vehicle without ESP®. The permissible axle loads, gross vehicle masses and center of gravity locations must be complied with.

Information on deactivating ESP® can be obtained from the responsible department (→ page 10).

Neither in the ready-to-drive condition nor with equipment installed nor with modifications having been carried out may the permissible wheel/axle loads or permissible gross masses of the vehicle ever be exceeded.

⚠ WARNING

If the permissible axle loads are exceeded, the ESP® system may not function correctly on vehicles which are equipped with this feature. This could cause the driver to lose control of the vehicle. There is a risk of accident, personal injuries, and death!"

Make sure that you do not exceed the permissible axle loads.

Following vehicle modifications which can result in changes to the longitudinal and lateral inclination (e.g. the installation of heavy parts), the sensor cluster must be recalibrated in order to ensure that the ESP® is functioning correctly.

Mercedes-Benz AG recommends that you have this work performed at a qualified specialist workshop.

Further information on the operating principle of the ESP® is available in Chapter 8.7.1 Electronic Stability Program (ESP®) (→ page 111).

- ① Additional information on permissible masses is available in the identification data on the vehicle (→ page 33).

3.6 Tires

The upfitter must ensure that:

- there is always sufficient space between the tire and the fender or wheel arch, even when snow or anti-skid chains are fitted and the suspension is fully compressed (also allowing for axle twist) (→ page 70) and that the relevant data in the 2D chassis drawings (offer drawings) are observed.
- only tire sizes approved by Mercedes-Benz (see Chapter 4.2.2 Approved tire sizes (→ page 51) are used.

In particular, comply with national regulations concerning the approval of tires. These regulations may define a specific type of tire for the vehicle or may forbid the use of certain tire types which are approved in other countries.

WARNING

Exceeding the specified tire load capacity or the permissible tire maximum speed can lead to tire damage or tire failure. This could cause you to lose control of the vehicle and cause an accident with possible injury to yourself and others.

Therefore only fit tires of a type and size approved by Mercedes-Benz for your vehicle model and observe the tire load capacity required for your vehicle and the tire speed rating.

If you have other wheels (not approved by Mercedes-Benz) fitted:

- the brakes or components of the suspension system could be damaged
- wheel and tire clearance can no longer be guaranteed
- the wheel brakes or components of the suspension system may no longer function correctly.

NOTE

If other tires are used (tires not approved by Mercedes-Benz for the vehicle model in question), some driver assistance systems may react incorrectly, with a delay or not at all.

For more information (→ page 12) and (→ page 50).

3.7 Threaded and welded connections

3.7.1 Threaded connections

For the threaded connections between the body and the basic vehicle or the vehicle frame, Mercedes-Benz recommends the use of flange bolts and flanged nuts.

If it is necessary to replace standard screws/nuts, only screws/nuts

- of the same diameter
- of the same strength grade
- of the same screw standard or type
- of the same surface coating (anti-corrosion protection, friction factor)
- with the same thread pitch

may be used.

We recommend the use of standard Mercedes-Benz parts.

⚠ WARNING

Do not modify any bolted connections that are relevant to safety, e.g. that are required for wheel control, steering or braking functions. They may otherwise no longer function correctly. This could cause the driver to lose control of the vehicle. There is a risk of accident, personal injuries, and death associated with such tampering and unauthorized installations!

Parts must be refitted in accordance with Mercedes-Benz service instructions and using suitable standard parts. We recommend the use of Mercedes-Benz genuine parts.

- VDI Directive 2862 must be applied to all installation work.
- It is prohibited to shorten the free clamping length, change to a stretch shank or use screws with a shorter free thread.
- The settling properties of threaded connections must be taken into account.
- Using Mercedes-Benz tightening torques requires the corresponding part that has to be screwed to have a total friction factor in the range $\mu_{\text{tot}} = 0.08$ to 0.14 .

- If screws are tightened to the required torque and tightening angle by Mercedes-Benz, a constructive modification is not possible.
- The Mercedes-Benz Workshop Information System (WIS) must be used to determine whether screws and nuts of suspension components must only be tightened when the vehicle is in ready-to-drive condition.
- Additionally clamped components of the body must exhibit an identical or higher strength than the previous clamped assembly.

i Information is available from any Mercedes-Benz Service Center.

⚠ WARNING

Screws or nuts with locking splines, microencapsulated bolts and self-locking nuts must always be replaced after a single use. Before new microencapsulated screws are screwed in, the mating thread must be recut or the nuts replaced to remove all residual screw locking compound. Finally, the recut through-tapped or blind-tapped holes must be blown out with air because any adhesive residue in the thread would prevent correct tightening of the screws.

If these instructions are not observed, bending forces could act on the screw due to the lack of pretension and cause the screw to break. The driver could lose control of the vehicle and cause an accident.

⚠ WARNING

There is an increased risk of injury when microencapsulated screws are loosened because of the sudden loosening of the screws. For this reason, ensure you have sufficient freedom of movement when loosening microencapsulated screws.

❗ For special screw connections, refer to the Mercedes-Benz Workshop Information System (WIS) (→ page 12) or contact the team “Technical advice on body compatibility” (→ page 10).

3.7.2 Welded connections

General

In order to maintain the high standard of welding demanded by Mercedes-Benz, the work must only be carried out by appropriately qualified welders.

For high-quality weld seams, we recommend that you:

- clean the area to be welded thoroughly
- make several short welding beads rather than one long bead
- make symmetrical beads to limit shrinkage
- avoid more than 3 welds at any one point
- avoid welding in strain-hardened zones

❗ NOTE

The battery must be disconnected before any welding work is carried out and airbags, the airbag control unit and seat belts must be protected from welding splashes or removed if necessary.

Choice of welding procedure

The mechanical properties of weld seams depend on selecting an adequate welding procedure and on the geometry of the elements to be joined.

If overlapping sheets are to be welded, the choice of welding procedure will depend on whether only one or both sides of the workpiece is/are accessible:

Accessible sides	1	Gas-shielded plug welding
	2	Resistance spot welding

Resistance spot welding

Resistance spot welding is used for welding overlapping parts which are accessible from both sides. Spot welding of more than two sheet layers must be avoided.

Distance between spot welds

To avoid shunt effects, the specified distances between the spot welds must be maintained ($d = 10e + 10 \text{ mm}$).

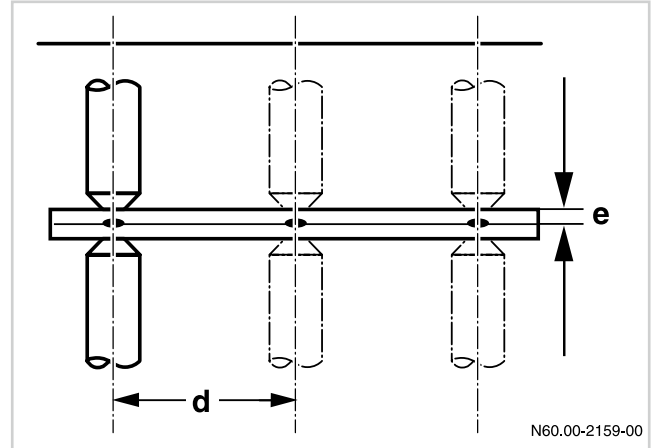

Sheet thickness

d Distance between spot welds

e Sheet thickness

Distance from sheet edge

To avoid melting core damage, the specified distances to the sheet edge must be maintained ($L = 3e + 2 \text{ mm}$).

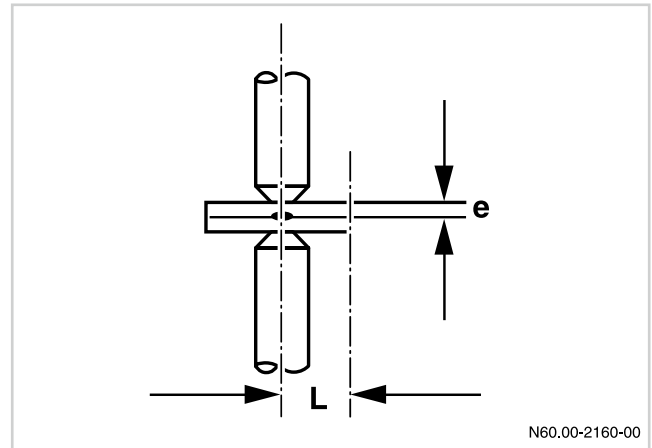

Sheet thickness

L Distance from sheet edge

e Sheet thickness

Gas-shielded plug welding

If overlapping sheets are only accessible from one side, use either gas-shielded plug welding or tack welding for the weld joint.

If the joint is produced by stamping or drilling followed by plug welding, the drilled area must be deburred before welding.

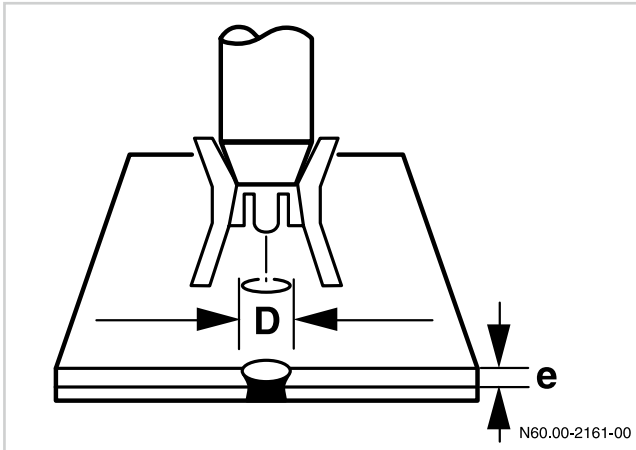

D = Plug hole diameter [mm]	4.5	5	5.5	6	6.5	7
e = Sheet thickness [mm]	0.6	0.7	1	1.25	1.5	2

Mechanical quality can be additionally improved by the use of "elongated holes" ($l = 2b$).

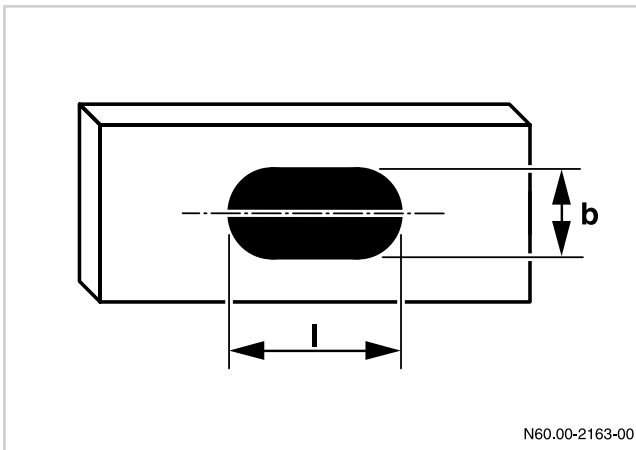

- b Width of elongated hole
- l Length of elongated hole

Tack welding

In case of sheet thicknesses > 2 mm, overlapping sheets may also be joined by tack welding ($30 \text{ mm} < L < 40e$; $d > 2L$).

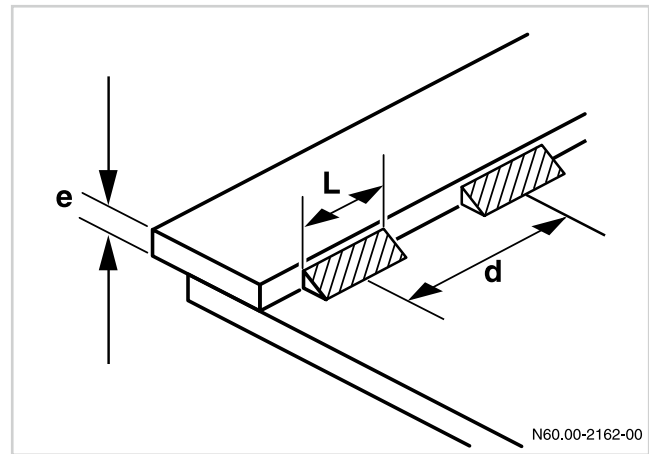

Dimensions for tack welds

- d Distance between tack weld centers
- e Sheet thickness
- L Length of tack weld

Do not perform welding work on

- major assemblies such as the engine, transmission, axles, etc.
- chassis frames except on longitudinal frame members for wheelbase modifications or overhang modifications.

i For additional information, see chapters 4 Technical limit values for planning (→ page 47) and 5 Damage prevention (→ page 54) and section 6.2 Body-in-white/body (→ page 66) as well as the Mercedes-Benz Workshop Information System (WIS) (→ page 12).

Anti-corrosion protection after welding

On completion of all welding work on the vehicle, you must comply with the specified anti-corrosion protection measures (→ page 57).

i NOTE

The instructions in Chapter 5 Damage prevention (→ page 54) and Chapter 6 Modifications to the basic vehicle (→ page 61) must also be observed for welding.

3.8 Soundproofing

If modifications are carried out on any parts whose operation produces noise, e.g.

- engine
- exhaust system
- intake air system
- tires, etc.

sound level measurements must be taken.

Local and national regulations and directives must be observed.

The following guidelines are recommended to be complied with:

- Noise-insulating parts fitted as standard must not be removed or modified.
- The level of interior noise must not be adversely affected.

! NOTE

To prevent modifications from changing the vehicle's sound levels, it must be ensured that interior sound levels are minimized when planning bodies (→ page 83).

3.9 Maintenance and repairs

Maintenance and repair of the vehicle should not be made unnecessarily difficult by the body.

The operator's manual must be observed.

- ▶ Maintenance points and major assemblies must be easily accessible.
- ▶ Stowage boxes must be fitted with maintenance flaps or removable rear panels.
- ▶ The battery box must be sufficiently ventilated, with provision for air to enter and exit.
- ▶ A battery vent should be installed if necessary.
- ▶ Check the condition and capacity of batteries and service them in accordance with the manufacturer's specifications (→ page 42).

! NOTE

Leaving the vehicle parked up for long periods of time can lead to battery damage. This can be avoided by disconnecting the battery and storing it in an appropriate manner (→ page 42).

Any additional work which arises due to the body in terms of warranty-related work, maintenance or repair work will not be paid for by Mercedes-Benz AG.

The following must be observed by the upfitter before delivery of the vehicle:

- Check the headlamp adjustment or have this checked at a qualified specialist workshop. We recommend a Mercedes-Benz Service Center.
- Retighten the wheel nuts/wheel bolts to the specified tightening torque.

Upfitter Management Vans recommends adapting the scopes of maintenance work on the body to each individual vehicle using the relevant Mercedes-Benz maintenance systems. This applies both to the scope and type of maintenance work, and for determining the service due dates based on time elapsed and mileage.

The upfitter must provide the vehicle with operator's manual and maintenance instructions for the body mounting work carried out and any additional major assemblies installed. These instructions must be in the language of the country in which the vehicle is to be used.

3.9.1 Storing the vehicle

Storage in enclosed premises

- ▶ Clean the overall vehicle
- ▶ Check the oil and coolant levels
- ▶ Inflate the tires to 0.5 bar above the specified tire pressures
- ▶ Release parking brake and prevent vehicle from rolling away with chocks

- Chapter 3.9.2 Battery maintenance and storage (→ page 42) must be observed.

Storing the vehicle in the open (< 1 month)

- ▶ Carry out the same procedure as for storing in an enclosed space.
- ▶ Close all air inlets and set the heating system to "Off".

- Chapter 3.9.2 Battery maintenance and storage (→ page 42) must be observed.

Storing the vehicle in the open (> 1 month)

- ▶ Carry out the same procedure as for storing in an enclosed space.
- ▶ Fold the windshield wipers away from the windshield
- ▶ Close all air inlets and set the heating system to "Off".

- Chapter 3.9.2 Battery maintenance and storage (→ page 42) must be observed.

3 Planning of bodies

Maintenance work on stored vehicles (in storage for > 1 month)

- Check the oil level once a month
- Check the coolant once a month
- Check the tire pressures once a month

Removing the vehicle from storage

- Check the fluid levels in the vehicle
- Adjust the tire pressures to the manufacturer's specifications
- Check the battery charge and install the battery
- Clean the overall vehicle

3.9.2 Battery maintenance and storage

For long non-operational times or storage, ensure that the battery is always in a charged state (at least 80% - corresponds to an open circuit voltage of approx. 12.55 V).

- ▶ If the vehicle is non-operational for periods of longer than 4 weeks, the batteries are to be charged in the vehicle via the jump-start connection point using a suitable charger.
- ▶ Alternatively, disconnect the batteries at the beginning of the non-operational time and, for periods of longer than 4 weeks, remove the batteries and store them in a dry place at temperatures of between 0°C/ 32°F and 30 °C/ 86°F. The batteries should be charged before being put into storage. The residual charging current should be less than 5 A and the voltage higher than 13.5 V.
- ▶ The batteries are to be recharged every 4 weeks in the installed state, or every 6 months if removed from the vehicle, until the residual charging current is less than 5 A.
- ▶ Store the battery in an upright position.
- ▶ The battery voltage must be kept above 12.55 V at all times.
- ▶ If the battery voltage drops below 12.55 V but not below 12.1 V, the battery must be recharged.

! NOTE

If the open circuit voltage (unloaded for 4 hours in the removed state) of the batteries drops below 11 V, they will be damaged and will have to be replaced.

3.9.3 Work before releasing the modified vehicle

The upfitter must confirm the work and modifications carried out by making an entry in the maintenance booklet.

Checking the overall vehicle

- ▶ Check the vehicle for perfect condition.
- ▶ Damage must be repaired where necessary.

Checking the brake system

- ▶ The brake fluid must be renewed regularly in accordance with the Mercedes-Benz specifications, but at least every two years.
- ▶ If it is not known how long the vehicle has been non-operational, the brake fluid must be renewed.
- ▶ Check electrical and hydraulic lines for damage of any kind and repair or replace if necessary.

Checking the vehicle electrical system

- ▶ After all work on the electrics or electronics, the fault memories of the control units must be read out and erased if necessary.

Checking the battery

- ▶ Check the battery charge level before handing over the vehicle. The battery must be recharged if necessary.

Checking the tires

- ▶ Before delivering the vehicle, check that the tires are inflated to the specified air pressure and check the tires for damage.
- ▶ Damaged tires must be replaced.

Checking wheel alignment

We recommend that the suspension geometry (toe adjustment etc.) be checked if modifications have been made by a body repair workshop.

- ① More detailed information is contained in the Mercedes-Benz Workshop Information System (WIS).

Deactivating transport mode

To avoid excessive discharge of the battery during lengthy non-operational times, the electrical system of Metris is in transport mode by default ex-factory, which is only deactivated just before the vehicles are delivered.

In transport mode the speed is limited to 40 km/h or 24.9 mph and not all the electrical and electronic systems are active. This results in a lower power consumption and reduces the load on the battery.

For Expert Upfitters where conditions dictate that the vehicles are idle for long periods of time, it is possible to deactivate transport mode not at the Mercedes-Benz service center, but at the upfitter site at the end of the non-operational period.

It is possible to use the vehicles in transport mode. However, please note that transport mode must always be deactivated before the vehicle is taken into service on public roads.

To deactivate transport mode with button combinations before the vehicle is taken into service:

- ▶ Turn the ignition key to position I (radio function active/terminal 15R).
- ▶ The hazard warning light system must be switched off.
- ▶ Activate the left turn signal indicator.
At least 2 blinking cycles.
- ▶ Activate the right turn signal indicator.
At least 2 blinking cycles.
- ▶ Switch off the turn signal indicator.
- ▶ Switch on the hazard warning light system.
At least 2 blinking cycles.
- ▶ Switch off the hazard warning light system.
- ▶ Activate the left turn signal indicator.
At least 2 blinking cycles.
- ▶ Activate the right turn signal indicator.
At least 2 blinking cycles.
- ▶ Switch off the turn signal indicator.
- ▶ Turn the ignition key to position II (ignition active/terminal 15).
- ▶ Check that the message "Transport Mode" is no longer displayed in the instrument cluster.



3.10 Special equipment

WARNING

The use of unapproved parts, major assemblies, conversion parts or accessory parts can have detrimental effects on the safety of the vehicle.





Before starting work on the vehicle, please read the chapters of the vehicle operator's manual relevant to installation and the operating and installation instructions from the manufacturers of accessories and special equipment. You could otherwise fail to recognize dangers which could result in injury to yourself or others.

We recommend using special equipment available as option codes to properly adapt the vehicle to the body.

-  More detailed information on special equipment can be found at:
 - Mercedes-Benz Service Center
 - Upfitter Portal (→ page 12)
 - 2.1 Advice for upfitters (→ page 10)
-  On the Mercedes-Benz homepage, you can assemble vehicles in the Configurator and view the available items of special equipment:

www.mbvans.com

Special equipment (e.g. reinforced springs, frame reinforcements, additional tanks, stabilizer bars etc.) or retrofitted equipment can increase the curb weight of the vehicle. Furthermore, special equipment can also alter the center of gravity, space availability and component clearances. Care must therefore be taken to preserve the functionality of the overall vehicle and to comply with the limit values (→ page 47) during all work on the vehicle.

-  The actual vehicle mass and axle loads must be determined by weighing before mounting.
-  On completion of all body mounting work, the measurement of the actual vehicle curb weight and the corresponding axle loads must be repeated by weighing. When doing this, comply with e.g. Chapter 9.1.1 Determination of the center of gravity in the x-direction (→ page 126).
-  The measured values must be documented.
-  With these values the specifications in the following chapters must be complied with or implemented:
 - "Dimensions and weights" (→ page 30) on the curb weight and the associated axle loads before and after the body mounting work,
 - "Checking wheel alignment" as per Chapter 3.9.3 Work before releasing the modified vehicle (→ page 42),
 - Chapter 4.2 Limit values for the suspension (→ page 50) and Chapter 6.1.1 General information on the suspension (→ page 61).

Not all auxiliary equipment can be installed in every vehicle without problems. This applies in particular in the case of retrofitting because the necessary installation space may be occupied by other components, or the special equipment may require additional components.

-  The team "Technical advice on body compatibility" (→ page 10) is available to answer any questions you may have.

3.11 Adhesive films on the exterior

The following specifications must be observed for adhesive films (wrapping) on the exterior of the vehicle:

- Films may only be applied to the exterior surfaces of the vehicle that are not labeled as impermissible areas in the schematic diagrams below. The Metris cargo van is illustrated as an example – applicable by analogy for other model designations.
- In areas with sensors, the attachment of adhesive film is generally not permitted; also refer to the notes on Collision Prevention Assist (code JA6) in Chapter 8.7.3 COLLISION PREVENTION ASSIST and DISTRONIC PLUS assistance systems (→ page 157), and on Blind Spot Assist (code JA7) and the pre-installation for Blind Spot Assist (code J1V) in Chapter 8.7.4 Blind Spot Assist (→ page 158).
- All local and national legal requirements of any kind pertaining to the application of films or similar materials on vehicles must be observed and complied with. In particular, the regulations on wrapping around the windshield, the windows and lighting systems must be adhered to.

⚠ WARNING

Depending on the type and thickness, paints or films can cause attenuation of radar waves. This could lead to malfunction or system failure. This could cause the driver to lose control of the vehicle.

There is a risk of accident!



Front of vehicle - speckled areas: Areas where wrapping is not permissible (example Metris cargo van, schematic diagram)

3 Planning of bodies

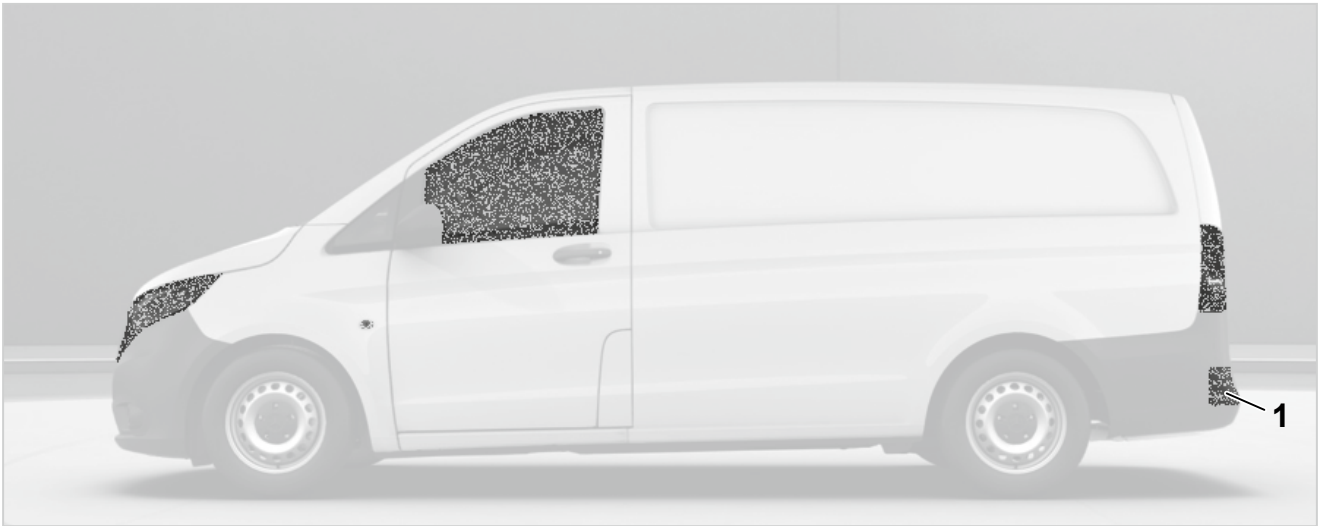

Sides of vehicle - speckled areas: Areas where wrapping is not permissible (example Vito Metris cargo, schematic diagram)

1 With Blind Spot Assist, code JA7



Rear of vehicle - speckled areas: Areas where wrapping is not permissible (example Metris cargo van, schematic diagram)

1 With Blind Spot Assist, code JA7

4.1 Limit values for the basic vehicle

! NOTE

This section contains the technical limit values of the basic vehicle which are important for planning work. In addition, the other chapters of the current version of the Body and Equipment Guideline must be observed.

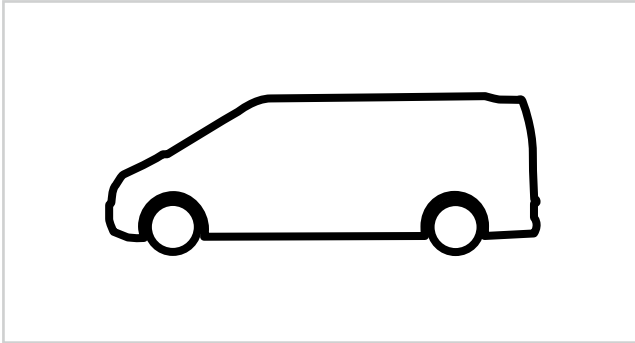

4.1.1 Steerability

- The front axle load must always be at least 35% of the current gross vehicle mass in all load states when the vehicle is moving.
- Make sure that you do not exceed the permissible axle loads.

! NOTE

Modifications must not be made to the steering system. This includes any change and/or limiting of the steering angle.

Modifications to the steering can cause the power steering assistance to fail.

4.1.2 Maximum permissible position of the center of gravity

x-axis:	Where $R_1 < 1700$ mm, 66.9 in (approx. 53% rear axle share of load) Where $R_2 < 1800$ mm, 70.9 in (approx. 53% rear axle share of load)
y-axis:	The maximum wheel load (1/2 the axle load) of the laden vehicle may only be exceeded by 4%.

R_1 = Wheelbase 1 (3200 mm, 126 in)

R_2 = Wheelbase 2 (3430 mm, 135 in)

The upfitter is responsible for determining and complying with the vehicle centers of gravity.

- ① For more information see Chapter 9.1.2 Determination of the center of gravity in the z-direction (→ page 128).

4.1.3 Maximum vehicle dimensions

It is the responsibility of the upfitter to ensure complete compliance with all federal, state, and local regulations for maximum vehicle dimensions.

4.1.4 Areas where welding is not permitted

- On the A and B-pillars
- On the upper and lower flange of the frame
- In bending radii
- In the vicinity of the airbags
- Plug welding is only permissible in the vertical webs of the longitudinal frame member.
- In the area of the support systems, e.g. the front and rear radars

Additional information can be found under 3.7 Threaded and welded connections (→ page 37) and 5.2 Welding work (→ page 55).

4 Technical limit values for planning

4.1.5 Areas of non-drilling

This chapter provides information about areas that should not be modified or changed due to safety and crash reasons.

Mercedes-Benz does not recommend drilling in the marked areas.

The following pictures show the safety and crash relevant areas.

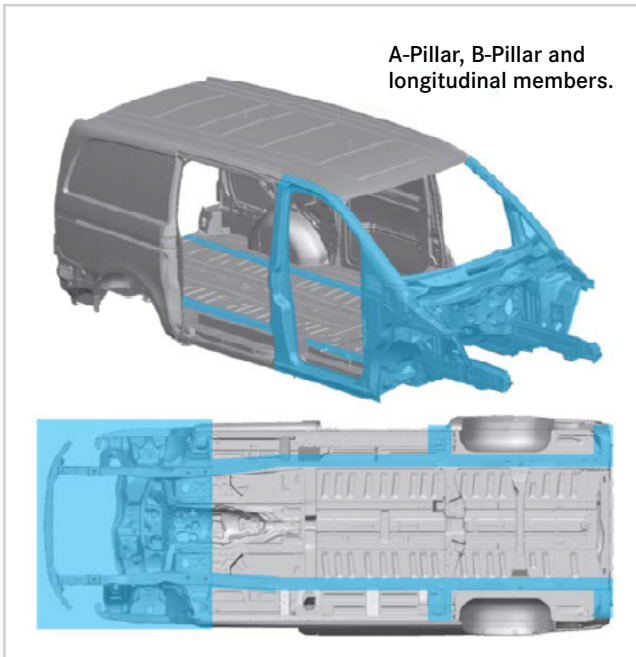

Safety and crash relevant areas (marked in blue)

The diagram below shows where drilling into the longitudinal member is not allowed.

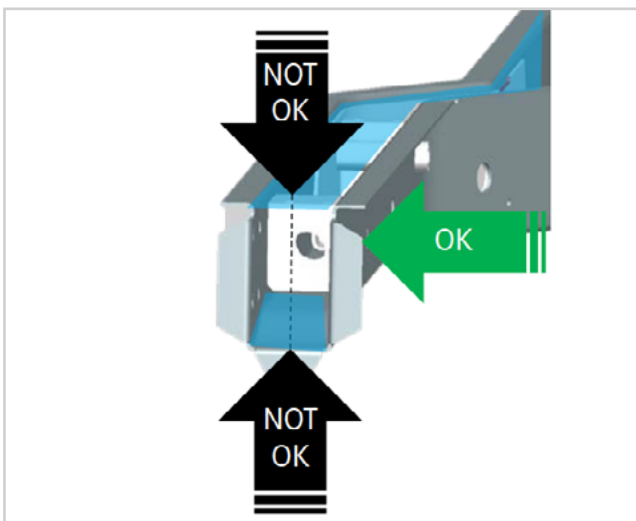

Longitudinal member, non-drilling areas

Drilling must not take place:

- At the A and B-pillars
- In the upper or lower flange/chord of the longitudinal frame member
- In the vicinity of load application points (e.g. spring brackets)
- In the vicinity of front axle or rear axle supporting points
- In the vicinity of the airbags
- In the area of the support systems, e.g. the front and rear radars

Mounting parts by drilling on the rear of the B-Pillar is permitted only if the integrity of the structure is unharmed. For mounting of partition walls, it is recommended to use existing holes and bore the existing holes to enlarge them.

! NOTE

Holes in the longitudinal frame member are the result of the production process and are not suitable for body mounting work. On no account may holes resulting from the production process be used as this could damage the frame.

! NOTE

Clearances for fuel filler necks, fuel tank lines, and fuel lines must be maintained. Sharp edges of the upfit can impact the fuel integrity of the vehicle.

4.1.6 Service lift support points

This section provides information about the service lift support points of the underbody.

- Vehicles that have been modified in the areas of maintenance points/lifting points are not serviceable at Mercedes-Benz dealerships.
- Due to safety reasons, Mercedes-Benz dealerships will not use any other lifting points than those designated by Mercedes-Benz standards.
- Mercedes-Benz highly recommends not to modify the highlighted areas.

For further Information and safety related questions, please review the applicable WIS document.

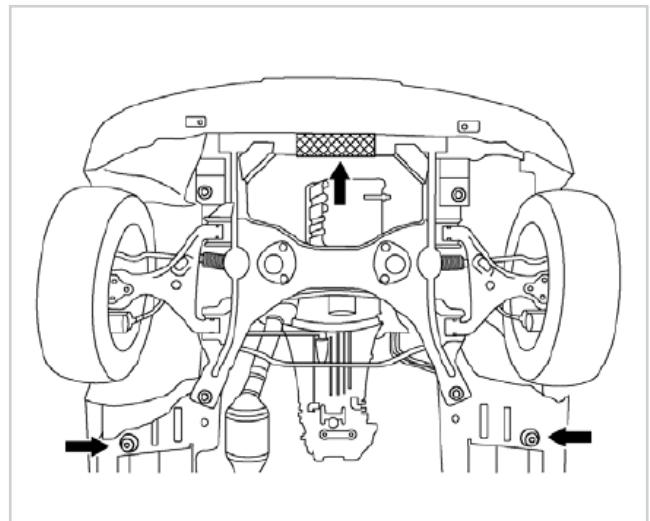

Illustration of front of vehicle



Illustration of left side of vehicle

- 1 Support plate
- 2 Twin post hoist support arm
- 3 Vehicle lift support point

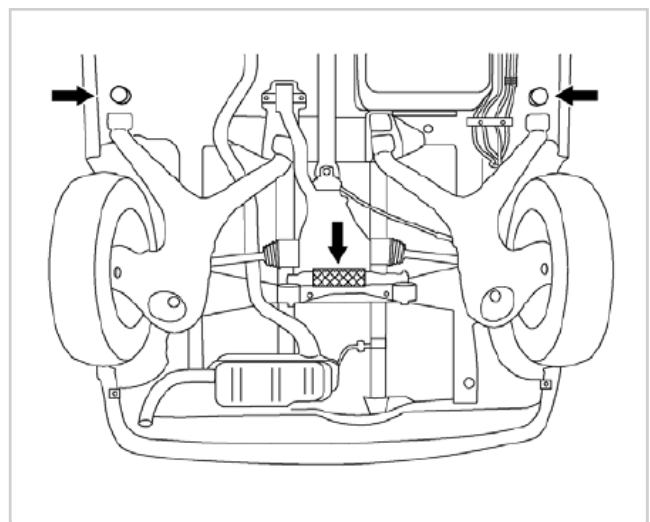

Illustration of front of vehicle



Illustration of right side of vehicle

- 4 Locking drift
- 5 Adapter

⚠ WARNING

Any modifications made to the service lift points may result in a risk of accident, personal injuries and death associated with such tampering and unauthorized installations!

4.2 Limit values for the suspension

4.2.1 Permissible axle loads

⚠ WARNING

If the permissible axle loads are exceeded, the ESP® system may not function correctly on vehicles which are equipped with this feature. Furthermore, any overloading may result in damage to the suspension and load-bearing parts. This could cause the driver to lose control of the vehicle. There is a risk of accident, personal injuries, and death!

Make sure that you do not exceed the permissible axle loads.

Information on axle loads and maximum permissible gross masses can be obtained from “Advice for upfitters” (→ page 10).

Metris				
Axle loads [t / lbs]	Cargo van		Passenger van	
Permissible gross mass	Front axle [kg / lbs]	Rear axle [kg / lbs]	Front axle [kg / lbs]	Rear axle [kg / lbs]
2.9 / 6393 (XA9)	1450 / 3197	1450 / 3197	1450 / 3197	1450 / 3197
3.1 / 6834 (XA8)	1550 / 3417	1550 / 3417	1550 / 3417	1550 / 3417

4.2.2 Approved tire sizes

Approved tire sizes for Metris

- i** Information about the tires/rims assigned to the vehicle model and any limitations can be obtained:
- from your contact persons, see Chapter 2.2.1 Upfitter Portal (→ page 12)

i NOTE

We explicitly remind you that the use of appropriate tire sizes only applies in the context of the weight and speed ratings approved and intended for these. Any changes and the latest tire values can be obtained from the Mercedes-Benz Vans dealership (→ page 10).

Approved tire sizes

Rim	Tire size
6.5J X 16	235/ 60 R16
6.5J X 17	235/ 55 R17
7J X 17	235/ 55 R17

4.2.3 Diameter of turning circle

The local and national regulations for vehicle approval and registration must be complied with.

Diameter of turning circle (wall to wall)

Version	Rear wheel drive (m/ ft)
Short (A2)	11.8 / 38.7
Long (A3)	12.5 / 41

Diameter of turning circle (curb to curb)

Version	Rear wheel drive (m/ft)
Short (A2)	11.1/ 36.4
Long (A3)	11.8/ 38.7

The size of your vehicle's turning circle can be found in the data sheets and 2D chassis drawings (offer drawings). Both sources of data are accessible through the Upfitter Portal (→ page 12).

4.2.4 Modifications to the axles

Modifications may not be made to the suspension or the axles (see Chapter 6.1 Suspension(→ page 61)).

4.2.5 Modifications to the steering

Modifications may not be made to the steering system (see Chapter 6.1 Suspension (→ page 61)).

i NOTE

No modifications should be made to the steering system. This includes any change and/or limiting of the steering angle.

Modifications to the steering can cause the power steering assistance to fail.

4.3 Limit values for the body-in-white

4.3.1 Modifications to the body-in-white

See Chapter 6.2 Body-in-white/body (→ page 66).

- No modifications may be made to the crossmember structure from the front of the vehicle back to, and including, the B-pillar.
- On no account should modifications be made to the rear portal including the roof area (→ page 69).
- In the event of modifications to the load-bearing structure, the total equivalent rigidity of the structure fitted by the upfitter must at least equate to that of the standard vehicle.
- Clearances for fuel filler necks, fuel tank lines and fuel lines must be maintained.
- It is not permissible to drill holes in or perform welding work on the A-pillar or B-pillar.
- If modifications are made to the side wall of the panel van or the crewbus, the rigidity of the modified body must be equal to that of the basic vehicle.

4.3.2 Roof/roof load

Maximum roof load for standard roof

150 kg / 330.7 lbs (with at least three pairs of support feet)

The figures indicated are applicable for even load distribution across the entire roof area.

With a shorter roof rack, the load must be reduced proportionally. The highest possible load per pair of roof rack support feet is 50 kg / 110.2 lbs.

The highest possible load of a railing carrier is 100 kg / 220.5 lbs.

Chapter 6.2.6 Modifications to the roof structure (→ page 70) must be observed when making modifications to the roof structure.

4.3.3 Limit values for the attachment point

The maximum tensile loading of the tie-down points only applies if the following conditions are fulfilled:

- The load located on the load compartment floor is secured at two tie-down points on the rail and
- The distance to the next load securing point on the same rail is approx. 1 m / 3.28 ft.

Maximum load forces

Code VV2	Load retainer rail system	500 daN / 1124 lbf
Code UR1	Seat rail system	300 daN / 674 lbf
Code V42	Tie-down rails, side wall to belt rail	100 daN / 224 lbf

4.4 Limit values for electrics/electronics

All electrical equipment fitted must be tested in accordance with the regulation UN R 10 as well as with national and local regulations.

i See also Chapter 8 Electrics/electronics (→ page 95).

4.4.1 Fuses

The following table is valid for cables with an operating temperature limit of more than 105°C / 221°F for the insulation.

Max. permanent current [A]	Fuse rating [A]	Line cross-section [mm ²]
0-4.9	5	0.5
5-9.9	10	1
10-18	20	2.5
19-28	30	4
29-35	40	6
36-48	50	10
49-69	70	16
70-98	100	25
99-123	125	35
124-148	150	50

4.4.2 Vehicle position lamps and side marker lamps

Vehicle marker and clearance lamps are required by law on all vehicles with total width of 2032 mm/80 inch and above according to FMVSS/CMVSS standards.

4.5 Limit values for additional assemblies

If additional assemblies (e.g. additional air-conditioning compressors, pumps) are retrofitted, the following must be observed:

- The operation of vehicle components must not be adversely affected.
- Unobstructed movement of the vehicle and detachable parts must be ensured in every driving situation.

i NOTE

When refrigeration systems/components are used in combination with R1234yf, all applicable laws, specifications, and safety regulations must be observed.

In particular, compliance with the safety regulations according to ISO 13043 at both the component and overall system level (FMEA, leak-tightness requirements, concentration measurements etc.) must be guaranteed.

In addition, it must be ensured that the safety requirements regarding inflammability and the risk of combustion associated with R1234yf are observed (best possible packaging and greatest possible distance from hot parts, installation of additional facilities, if necessary, to ensure that required level of safety).

If R1234yf is used, a specific information label with details of the quantity and combustion risk must be considered or installed in a visible location.

5.1 Brake hoses/cables and lines

! NOTE

Any work carried out on the vehicle must comply with accident prevention regulations.

! NOTE

Comply with all national directives and laws.

Cover plastic lines and brake hoses before carrying out any welding, drilling and grinding work or before working with cutting disks. If necessary, the plastic lines and brake hoses should be removed.

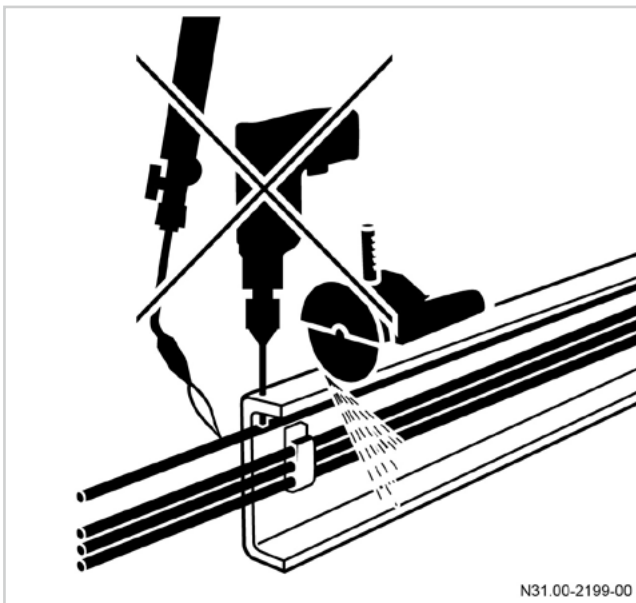

Test each of the systems for pressure loss and leak tightness after installing compressed-air lines and hydraulic lines.

No other lines may be attached to brake hoses and brake lines.

No other lines may be attached to brake lines, other than those installed as standard.

Lines must be protected from heat by means of insulation.

⚠ WARNING

Work carried out incorrectly on the brake hoses or cables may impair their function. This may lead to the failure of components or safety-relevant component parts. There is a risk of accident, personal injuries, and death associated with such tampering and unauthorized installations!

Have all work on brake hoses and cables carried out at a qualified specialist workshop.

5.2 Welding work

⚠ WARNING

Welding in the vicinity of the restraint systems (airbag or seat belts) can cause these systems to no longer function correctly.

If restraint systems no longer function correctly, the occupants may be unprotected in the event of an accident. There is a risk of accident, personal injuries and death associated with such tampering and unauthorized installations!

Welding is therefore not permitted in the vicinity of the restraint systems.

⚠ WARNING

Welding work that is not performed correctly could lead to failure of components relevant to safety. It would then not be possible to rule out the risk of an accident. There is a risk of accident, personal injuries and death associated with such tampering and unauthorized installations!

Have welding work carried out by a qualified specialist workshop.

⚠ WARNING

If handled incorrectly, welding work can result in a fire. There is a risk of accident, personal injuries and death associated with such tampering and unauthorized installations!

Always comply with the legal requirements when performing welding work.

For this reason, the following safety measures must always be observed during any work involving welding:

- Welding on the vehicle may only be carried out by trained personnel.
- Before carrying out welding work, components which may contain flammable or explosive gases - e.g. the fuel system - must be removed or protected against sparking with a fire-resistant covering. Components which are damaged by sparking during welding work must be replaced.
- Before welding operations in the vicinity of the seat belts, airbag sensors or the airbag control unit, these components must be removed for the duration of the work. You will find important information about handling, transporting and storing airbag units under Chapter 6.4 Interior (→ page 76).
- Before welding, cover springs and air suspension bellows to protect them from welding spatter. Do not touch springs with welding electrodes or welding tongs.
- No welding work must be carried out on major assemblies such as the engine, transmission, axles, on the lower flange of the frame or on the A-pillar and B-pillar.
- Disconnect the positive and negative terminals from the batteries and cover them.
- Connect the welder ground clamp directly to the part to be welded. Do not connect the ground clamp to major assemblies such as the engine, transmission or axles.

5 Damage prevention

- Do not touch electronic component part housings (e.g. control units) and electric lines with the welding electrode or the ground clamp of the welder.
- Weld only with electrodes connected to the positive pole of a direct current source. Always weld from bottom to top.
- The maximum current may be 40 A per mm of electrode diameter.
- Use only completely dry basic-coated electrodes (diameter 2.5 mm / 0.098 in).
- Gas-shielded welding is possible.
- Only use welding wires with a thickness of between 1 and 1.2 mm or 0.039 and 0.047 in.
- The yield and tensile strength of the welding material must be at least equal to that of the material to be welded.
- Plug welding is only permissible in the vertical webs of the longitudinal frame member.
- Weld seams must be ground down and reinforced with angular profiles to prevent notching from welding penetration.
- Do not perform any welding work in bends.
- There must be at least 15 mm / 0.591 in between the weld seams and the outer edges.

 For further information on welding, refer to chapter Chapter 3.7 Threaded and welded connections (→ page 37) and the Mercedes-Benz Workshop Information System (WIS).

5.3 Anti-corrosion protection measures

Surface and anti-corrosion protection measures must be carried out on the affected areas after modifications and installation work have been performed on the vehicle.

NOTE

Only preservation agents tested and approved by Mercedes-Benz may be used for any anti-corrosion protection measures performed.



ENVIRONMENTAL NOTE

Since July 1, 2007, surface protection (e.g. also according to DBL 9440.40) is no longer allowed to contain chromium 6.

Planning measures

Anti-corrosion protection measures should be included in the planning and design stages by selecting suitable materials and designing components accordingly.

- ① A galvanic connection occurs if two different metals are brought into contact with each other through an electrolyte (e.g. air humidity). This causes electrochemical corrosion and the less noble of the two metals is damaged. The further apart the two metals are in the electrochemical potential series, the more intense electrochemical corrosion becomes.
- ① For this reason, electrochemical corrosion must be prevented by insulation or by treating the component parts accordingly, or it can be minimized by selecting suitable materials.

Preventing contact corrosion by means of electrical insulation

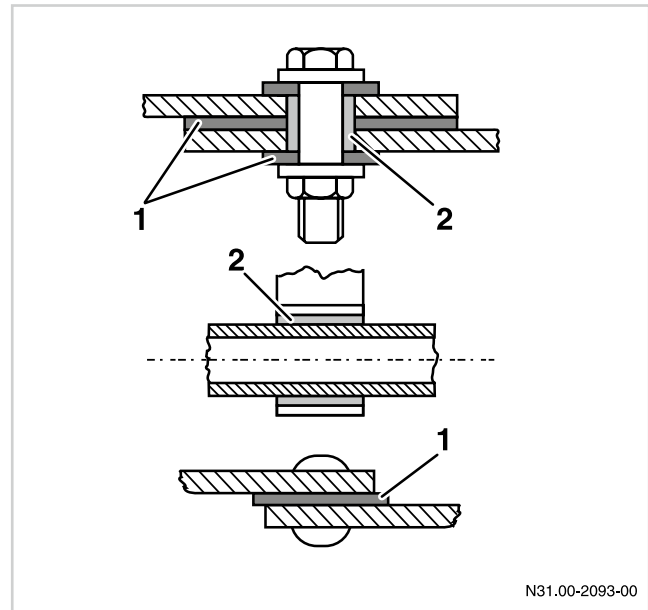

Preventing contact corrosion

- 1 Insulating washer
- 2 Insulating sleeve

Contact corrosion can be prevented by using electrical insulation such as washers, sleeves or bushings.

Avoid welding work on inaccessible cavities.

Component design measures

Corrosion can be prevented by design measures, in particular the design of joints between identical or different materials.

There is a risk of dirt or moisture accumulating in corners, edges, creases and folds.

Design measures for counteracting corrosion should be implemented using inclined surfaces and drains, and by avoiding gaps in the joints between components.

Gaps inherent in the design of weld joints and how to avoid them

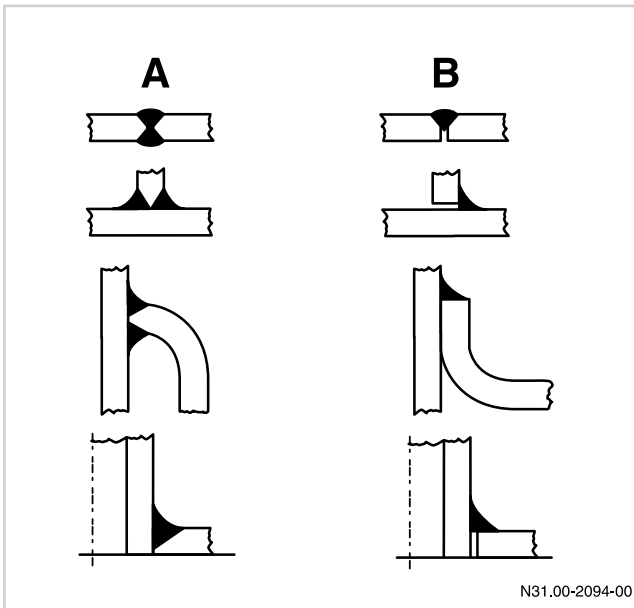

Examples of types of weld joints

A = correct
(through-welded)

B = incorrect
(gap)

Coating measures

The vehicle can be protected against corrosion by applying protective coatings (e.g. galvanization, painting, preservation or zinc coating applied by flame) (→ page 59).

After all work on the vehicle:

- ▶ Remove drill chips.
- ▶ Deburr edges.
- ▶ Remove any burned paint and thoroughly prepare surfaces for painting.
- ▶ Prime and paint all unprotected parts.
- ▶ Preserve cavities with wax preservative.
- ▶ Carry out anti-corrosion protection measures on the underbody and frame parts.

Measures for drilling through the body

Whenever an assembly hole is made in the vehicle body, one or more elements of the existing protection system is/are irreparably damaged.

The upfitter making the modification is therefore obliged to restore the quality of the corrosion protection system to that of the basic vehicle.

1. Protect the exposed panel edge

- ▶ Remove drill chips.
- ▶ Deburr the hole.
- ▶ Prepare the surface: Degrease the edge of the panel and adjacent areas for painting.
- ▶ Prime and paint all unprotected parts (phosphate-containing base coat).

2. Ensure the leaktightness of the drilled hole if it is exposed to the outside

- Use round bodywork sealing cord between the installed parts and the body (except roof ventilation elements)
- Use silicone for the floor ventilation element
- ▶ Spray underbody protection on all attaching parts which project downward out of the vehicle.

The proper application of these measures will ensure that the basic vehicle remains free of rust for many years.

Additional recommended anti-corrosion protection measures in vehicle floor area

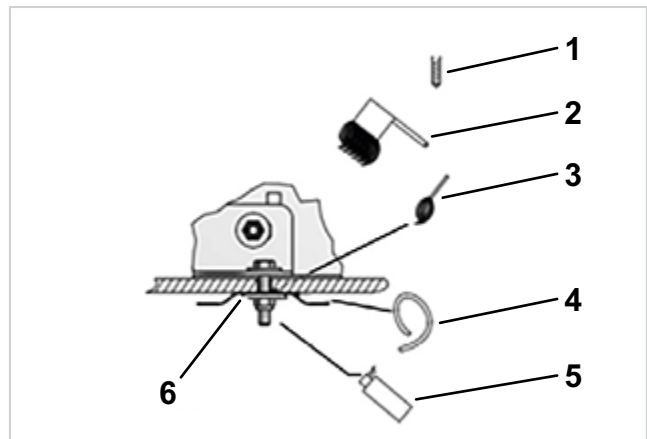

Steps for anti-corrosion protection of floor mounting

1. Drilling
2. Remove/suction off drill chips
3. Prime and paint all unprotected parts
4. Use round bodywork sealing cord under the shim plate
5. Spray underbody protection on all attaching parts which project downward out of the vehicle
6. Shim plate

5.4 Painting work/preservation work

! NOTE

To dry the paint, an air circulation temperature of 80°C / 176°F and a component temperature of 60°C / 140°F must not be exceeded. Control units or other components can be damaged at higher temperatures.

Paintwork or preservation damaged by the upfitter must be repaired by the upfitter.

Observe the following points:

- Mercedes-Benz quality standards for initial painting and repair paintwork must be adhered to.
- Only materials tested and approved by Mercedes-Benz or equivalently suitable materials may be used for any painting or preservation work performed.
- The upfitter must observe the coat thickness for each individual coat as specified by the factory.
- Paint compatibility must be guaranteed when repainting.

i You can obtain information on the paint materials and coat thicknesses used at the factory and Mercedes-Benz paint numbers from any Mercedes-Benz Service Center.

Mask the following areas before painting:

- Disk brakes
- Brake hoses
- Brake fluid reservoir
- Gearing unit for parking brake
- Contact surfaces between disk wheels and wheel hubs/brake disks
- Contact surfaces of wheel nuts/wheel bolts
- Airbags and seat belts
- Sealing surfaces
- Windows, mirror glass
- Illumination openings
- Breathers on transmissions, axles, etc.
- Door locks
- Door catches in the hinges of the rear-end door
- Contact surfaces on the guide rails of sliding doors
- Door retainers and opening limiters in the center guide rails
- Moving parts of the sliding door carriage
- Coupling flanges of drive shafts and power take-offs
- Piston rods e.g. on gas-operated springs of liftgate
- Pneumatic control valves (compressed-air system/vacuum system)
- Spring/spring seat area
- PARKTRONIC sensors

5.4.1 Application of decals

When applying decals to the exterior of the vehicle, the upfitter should ensure compatibility to the vehicle paint.

Please note the following points during decal application:

- Ensure that the surface is clean before applying (free of fingerprints, grease, oil etc.)
- Check the decal material supplier's recommendations for an appropriate cleaning solution mixture
- Apply adequate contact pressure at every point on the vinyl surface to reduce risks of failure
- It is recommended to test at various extreme environmental conditions when choosing an appropriate material for decals (consider temperature, humidity, etc.)

6.1 Suspension

6.1.1 General information on the suspension

⚠ WARNING

Modifications to suspension system components can result in impaired and unstable vehicle handling characteristics. This could cause the driver to lose control of the vehicle.

There is a risk of accident, personal injuries, and death associated with such tampering and unauthorized installations!

For this reason, no modifications whatsoever may be made to components of the suspension system.

This is especially valid for:

- Front transverse control arms: Changes to wheel alignment settings are not permitted.
 - Front axle carrier: It is not permitted to modify or use the front axle carrier to mount additional assemblies or make other modifications.
 - Stabilizer bars: Modifications are not permitted.
 - Rear axle: Modifications are not permitted.
 - Brakes: Modifications are not permitted.
 - Units, sensors, line installation for ESP®/ABS: Modifications are not permitted.
 - New screws must be used when installing the front axle. All bolts and threaded connections are to be tightened in accordance with the Mercedes-Benz tightening instructions. Information on this is available from your Mercedes-Benz Service Center.
 - VDI guideline 2862, in particular, the chapter entitled "Threaded connections with special safety relevance", must be implemented for all installations.
- It is prohibited to shorten the free clamping length, change to a stretch shank or use screws with a shorter free thread.
 - The settling properties of threaded connections must be taken into account.
 - Additionally clamped component parts must exhibit an identical or higher strength than the previous clamped assembly.
 - The use of Mercedes-Benz tightening torques assumes coefficients of friction for the bolts in the tolerance range ($\mu = 0.08$ to 0.14).
 - We recommend the use of Mercedes-Benz genuine parts.

- ① Further information, in particular about Mercedes-Benz tightening instructions and the settling properties of threaded connections, can be requested from any Mercedes-Benz Service Center.

! NOTE

In order to prevent tire wear, a change in the standard wheel alignment values (camber, toe-in) at the front axle can be economical in the case of vehicles with increased curb weight due to body or equipment.

The information under 3.3 Dimensions and weights (→ page 30) on the vehicle curb weight and corresponding axle loads before and after body mounting work, "Checking wheel alignment" under 3.9.3 Work before releasing the modified vehicle (→ page 42) and 3.10 Special equipment (→ page 44) must be complied with.

Examples of this are recovery vehicles, fire-fighting vehicles, ambulances, rescue vehicles, workshop vehicles or recreational vehicles. For a planned change in the standard wheel alignment values, consulting a Mercedes-Benz partner is recommended. Based on the exact axle load conditions of the complete vehicle, the Mercedes-Benz partner can determine the ideal camber and toe-in values based on the workshop documents stored in the Workshop Information System (WIS) (→ page 12).

The same applies to fully laden vehicles as it can be assumed that the maximum permissible axle loads are mainly marginally utilized here as well.

6.1.2 Springs/shock absorbers

Modifications to spring suspension, shock absorbers, and stabilizers using non-Mercedes Benz parts are not recommended.

If modification to the suspension system is desired, then only Mercedes-Benz parts must be used. When replacing the suspension package, the entire suspension system must be replaced including all the relevant parts and the software system. Please reach out to the local dealership for obtaining all the necessary parts and flashing of the software system. On no account should modifications be made to the spring mountings.

⚠ WARNING

On no account should springs and shock absorbers be used if they do not correspond to the characteristics of standard parts or parts obtainable as special equipment. Otherwise, if the vehicle is fitted with ESP[®], this system may no longer work correctly and could ultimately fail. This could cause the driver to lose control of the vehicle. There is a risk of accident, personal injuries, and death!

! NOTE

Refer also to the special equipment available ex-factory as a code (→ page 44).

6.1.3 Brake system

⚠ WARNING

Work carried out incorrectly on the brake lines or brake hoses may impair their function (this includes lines for hydraulic components, air or electrical control signals). This may lead to the failure of components or safety-relevant component parts. This could cause the driver to lose control of the vehicle. There is a risk of accident, personal injuries, and death associated with such tampering and unauthorized installations!

Work on brake lines or brake hoses may only be carried out by an authorized specialist workshop.

After completion of the work, check that the brake system is working correctly. We recommend that the brake system be inspected and approved by a technical inspection station.

If the routing has to be altered, avoid routing across sharp edges and through narrow cavities or near moving components.

Hydraulic brake system

- Hydraulic brake lines must be replaced without additional connecting points using Mercedes-Benz-approved double-walled wrapped tubes of 4.75 mm x 0.7 mm (0.187 in x 0.028 in) or fully assembled brake lines with connecting parts (Mercedes-Benz genuine parts). The brake lines from the master brake cylinder to the hydraulic unit must not be replaced!
- Brake lines between the master brake cylinder and the hydraulic assembly must not be modified.
- The bending radius must be >18 mm (0.709 in).
- Lines must only be shaped in a bending machine. The cross-section must not be reduced.
- Use retaining screws (Mercedes-Benz genuine parts) at the ends of lines and make a flange .
- The inside of the lines must be cleaned before installation.

- The use of plastic lines in hydraulic systems is not permissible.
- The brake fluid must be renewed regularly in accordance with the Mercedes-Benz specifications, but at least every two years. If necessary, renew the brake fluid before delivery to the customer.
- If the change interval of the brake fluid has been exceeded or if the age of the brake fluid is unknown, the brake fluid must be replaced.
- For routing between two components which move in relation to each other, a high-pressure-resistant flexible line (brake hose, genuine Mercedes-Benz brake components if possible) must be used. Make sure that the flexible lines are not placed under stress in any operating statuses and cannot chafe against other component parts.

Routing of lines

WARNING

A sufficient distance must be maintained between brake lines and heat sources, sharp-edged or moving parts. Otherwise the brake system function could be impaired or the brake system could suffer total failure as a result of bubbles forming in the brake fluid or from chafe marks in the brake lines.

This could cause the driver to lose control of the vehicle. There is a risk of accident, personal injuries, and death!

Work on brake lines may only be carried out by an authorized specialist workshop.

- We recommend the use of genuine Mercedes-Benz brake line brackets for the attachment of the brake lines.
- The maximum permissible distance between straps is 500 mm or 19.7 in.
- The brake lines must be routed without kinks.

Routing lines along the brake hoses and brake lines

No other lines may be attached to brake hoses and brake lines.

Brake cable for the parking brake/modifying the length of the brake cable

- If a new brake cable is required for the parking brake, the new length of the cable must be determined and a suitable new cable must be procured.
- The brake cable retainers are moment-optimized; modifications are not permitted.
- The brake cables must be routed without kinks.
- There must be no angle changes at the end pieces of the brake cable conduit.
- No other lines may be attached to brake lines, other than those installed as standard.

 Please address all queries regarding production brake cables to the department responsible (→ page 10).

Disk brakes

Cooling must not be impaired by attaching spoilers below the bumper, additional wheel trims or brake disk covers, etc.

⚠ WARNING

On no account should modifications be made to the air inflow and air outflow of the brake system. Any modifications to the steering and the brake system may result in these systems malfunctioning and ultimately failing. This could cause the driver to lose control of the vehicle.

There is a risk of accident, personal injuries, and death associated with such tampering and unauthorized installations!

For this reason, make sure that there is a sufficient supply of cooling air at all times.

For modifications which impair the flow of cooling air to the brake system, please contact the Upfitter Management Vans team. (→ page 10).

⚠ WARNING

Any modifications to brake components may result in these systems not functioning correctly and ultimately failing. This could cause the driver to lose control of the vehicle.

There is a risk of accident, personal injuries, and death associated with such tampering and unauthorized installations!

Modifications to brake system components are not permitted.

6.1.4 Air suspension

⚠ WARNING

On no account should springs and shock absorbers be used if they do not correspond to the characteristics of standard parts, certified components or parts obtainable as special equipment. This applies in particular to the retrofitting of air suspension to the front axle. Otherwise, if the vehicle is fitted with ESP[®], this system may no longer work correctly and could ultimately fail. This could cause the driver to lose control of the vehicle. There is a risk of accident, personal injuries, and death associated with such tampering and unauthorized installations!

6.1.5 Wheels/tires

- ⓘ Only fit tires of a type and size approved by Mercedes-Benz for your vehicle model and observe the tire load capacity required for your vehicle and the tire speed rating.

In particular, comply with local and federal regulations concerning the approval of tires. These regulations may define a specific type of tire for the vehicle or may forbid the use of certain tire types which are approved in other countries.

If you have other wheels (not approved by Mercedes-Benz) fitted,

- the brakes or components of the suspension system could be damaged.
- wheel and tire clearance can no longer be guaranteed.
- the wheel brakes or components of the suspension system may no longer function correctly.

The upfitter must ensure that the following requirements are fulfilled:

- There must be sufficient space between the tire and the fender and/or wheel well even with snow or anti-skid chains fitted and the suspension fully compressed (allowing for axle twist). For this, the relevant specifications in the 2D chassis drawings (offer drawings) must be observed.
- Only tires and tire sizes approved by Mercedes-Benz may be used (see vehicle registration document, 2D chassis drawings (offer drawings) (→ page 12), or the tables under 4.2.2 Approved tire sizes (→ page 51)).
- It is only permissible to fit approved wheels.

i You can obtain more information about tires and wheels from any Mercedes-Benz Service Center or under Chapter 3.10 Special equipment (→ page 44).

! NOTE

Mercedes-Benz explicitly reminds you that the use of appropriate tire sizes only applies in the context of the weight and speed ratings approved and intended for these.

6.1.6 Spare wheel

Country-specific equipment or special equipment may include a spare wheel.

For the attachment, the following requirements shall be complied with in addition to the legal directives:

- The attachment shall take place under the frame as per the 2D drawing.
- Good accessibility and ease of operation must be ensured.
- The spare wheel must be doubly secured to prevent loss.

Brief descriptions of some of the new features in the vehicle can also be found in the Upfitter Portal.

The Upfitter Portal can be accessed at the following link:

www.UpfitterPortal.com

6.2 Body-in-white/body

6.2.1 General information on the body-in-white/body

Modifications must not have a negative effect on the function or strength of vehicle equipment or controls or on the strength of load-bearing parts.

In the case of modified vehicles, it is not permissible to make modifications that affect the function or freedom of movement of vehicle parts (e.g. during maintenance and inspection work) or accessibility of these parts.

Observe the following:

- Changes to the wheelbase are not permitted.
 - The maximum permissible axle loads must not be exceeded.
 - On no account should any modifications (such as drilling or welding) be carried out on the support structure from the front through to the rear of the B-pillar.
 - Modifications to the windshield and windshield frame, and to the A-pillar and B-pillar, are not permissible.
 - Holes in the longitudinal frame member are the result of the production process and are not suitable for fastening bodies; otherwise a risk of damage to the frame.
 - It is not permissible to make cuts in the C or D-pillar (rear portal), including the associated roof bows.
 - Subsequent modification of vehicles with window air-bag is not permissible in the roof area of the B-pillar.
 - Partitions may be totally or partially removed.
- The clearance of the fuel filler neck, fuel tank and fuel lines must be maintained, see Chapter 6.3.1 Fuel system (→ page 72).
 - Avoid sharp-edged corners.
 - Trailer connections must be checked for correct operation.
 - If a genuine Mercedes-Benz trailer coupling is installed, the necessary reinforcements must be present (→ page 90).
 - For fastening retrofit installations in the vehicle interior, the seat mounting supports of the 1st and 2nd rear seat rows and the standard-equipment tie-down eyes and their mounting points are to be used first.
 - Brackets (plug welds) must be used to attach additional equipment to the longitudinal and cross-members.
 - The function of the tire pressure monitoring system (TPMS) must not be impaired by modifications made in the direct proximity of the antennas and wheels.

Welding work on the body-in-white

Welding work may only be performed by trained personnel.

When performing welding work, Chapter 5.2 Welding work (→ page 55) must be observed. In addition, you can find information on the design of weld joints in Chapter 3.7 Threaded and welded connections (→ page 37).

Drilling work on the body-in-white

! NOTE

No drilling must take place in the following areas:

- A-pillars and B-pillars
- The lower flange of the frame
- In the vicinity of the rear axle which performs a load-bearing function
- In the vicinity of components which are mounted on the frame
- Load application points (e.g. spring brackets, brackets)

Drilling in the longitudinal member web is only possible in accordance with the following illustration and if spacer bushings welded to the longitudinal member are used:

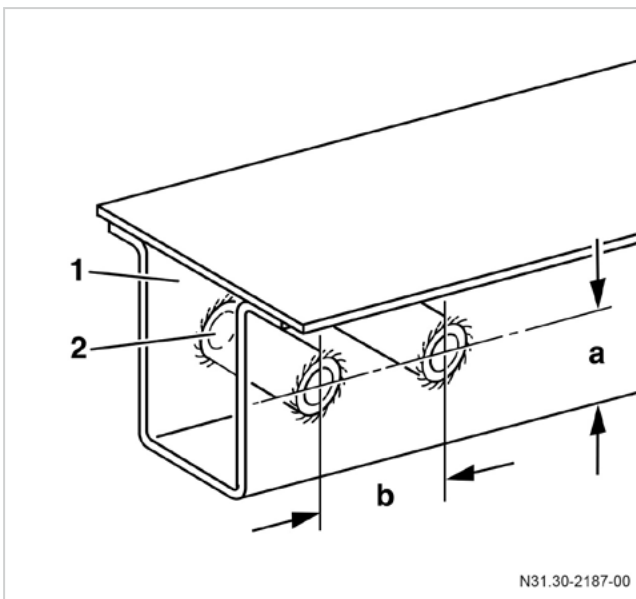

Drilling work on the longitudinal frame members

- 1 Chassis frame
- 2 Spacer bushings
- a Distance of at least 20% of the frame height
- b Distance between bores at least 50 mm or 1.97 in

- ▶ After drilling, deburr and countersink all holes, remove chips from the frame and treat the holes with body cavity sealing.

! NOTE

Existing holes in the longitudinal frame member result from the production process and may only be used after review from the responsible department through the Upfitter Portal. (→ page 12).

▲ WARNING

Drilling in the vicinity of the restraint systems (airbag or belts) can cause these systems to no longer function correctly.

If restraint systems no longer function correctly, the occupants may be unprotected in the event of an accident. There is a risk of accident, personal injuries and death if such restraint systems no longer function correctly!

Drilling is therefore not permitted in the vicinity of the restraint systems.

6.2.2 ISO conformity of partition

Vehicles registered as commercial vehicles without a partition do not satisfy the requirements of DIN ISO 27956, which describes the fixtures for the proper securing of cargo in delivery vans. If the vehicle is to be used for the carriage of goods, the retrofitting of a partition is urgently recommended because it is extremely difficult to implement the proper securing of loads in vehicles without a partition.

If retrofits, modifications or attachments of any kind are performed on the partition, compliance with DIN ISO 27956 is highly recommended. We recommend having this confirmed by an authorized testing organization.

If the partition is removed, the vehicle will no longer comply with DIN ISO 27956. In this case, the tie-down eyes must be installed.

If the partition/divider is modified or has parts attached to it, or if it is retrofitted or removed, the functioning of safety equipment (e.g. the deployment areas of airbags) must not be affected (see Chapter 6.4.2 Safety equipment (→ page 77)).

6 Modifications to the basic vehicle

In these cases the upfitter must ensure that the product satisfies the requirements of a safe product, if necessary by means of other measures as he or she sees fit. In this respect, the ISO standard represents only the technical minimum standard.

- Additional information on special equipment can be obtained from your Mercedes-Benz Service Center, from the relevant department (→ page 10) or under Chapter 3.10 Special equipment (→ page 44).

⚠ WARNING

On no account should subsequent modifications be made to the headliner or roof panel if the vehicle is equipped with window airbags. Otherwise, the window airbag may no longer work correctly (e.g. window airbag deployment is delayed or incomplete).

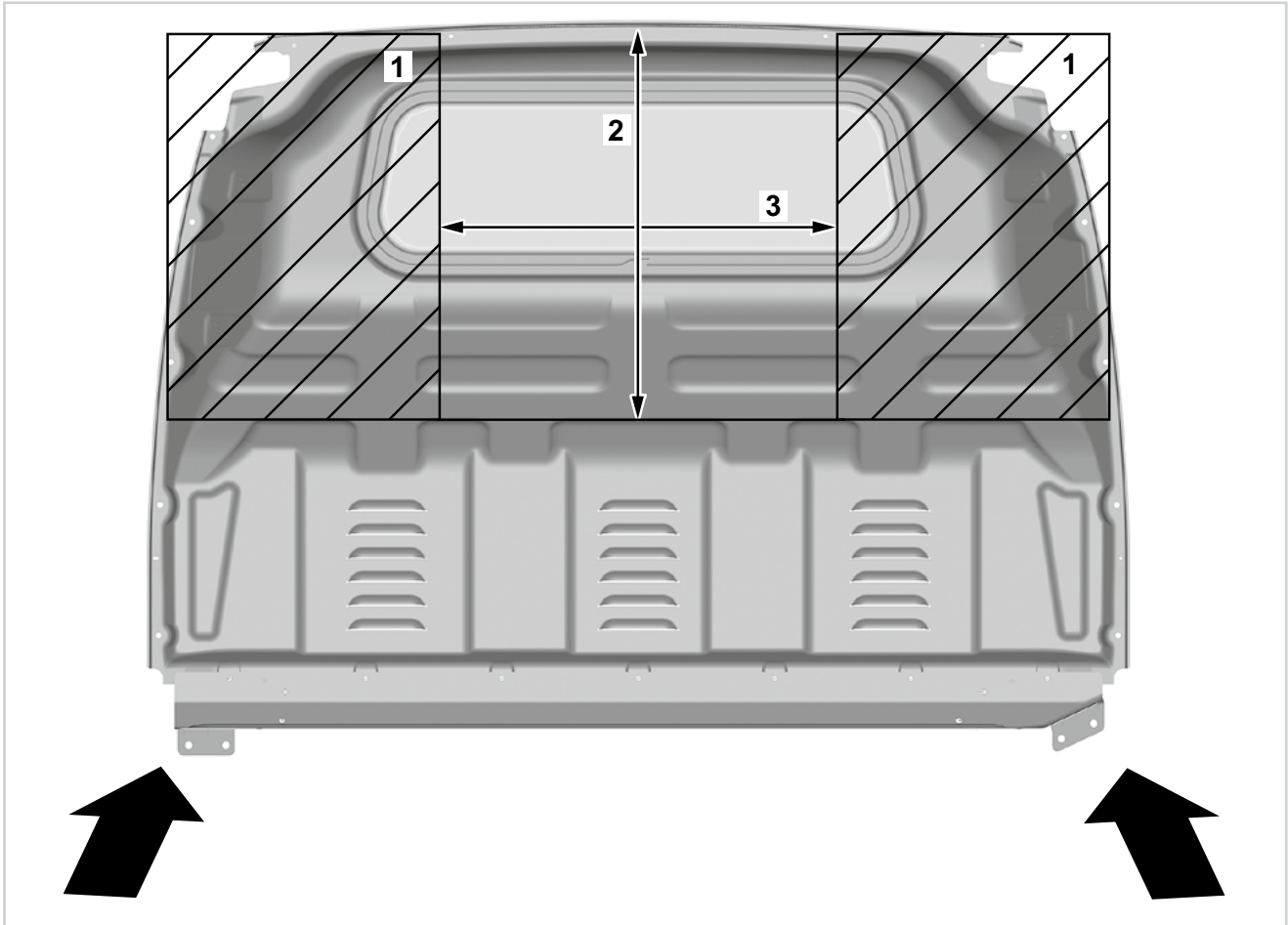

N68.74-2024-00

- 1 Areas which must not be modified on vehicles with window airbags
- 2 Vertical dimension (from the highest point of the vehicle roof, interior, at the height of the B-pillar): 650 mm or 25.59 in
- 3 Horizontal dimension: 800 mm or 31.50 in

6.2.3 Side wall, windows, doors and flaps

Side wall

If modifications are made to the side wall of the cargo van or the passenger van, the rigidity of the modified body must be equal to that of the basic vehicle.

The roof frame must be retained and its function may not be impaired in any way.

Refer to Chapter 8.7.2 Crosswind Assist (→ page 112) for modifications to the projected lateral face.

NOTE

Upon completion of all work on the vehicle, you must comply with the specified anti-corrosion protection measures (→ page 57).

- i** Additional information on modifications to the side wall can be found under Chapter 6.6.3 Shelf systems (→ page 85).

Windows

Windows must be inserted with a stable frame. The frame must then be joined by a non-positive attachment to other body elements.

If modifications need to be carried out to the supporting structure of the basic vehicle (pillars, reinforcements, attachment of roof bows) in order to retrofit windows (panoramic glazing), the rigidity of the modified body must be equal to that of the basic vehicle.

Laminated glass is regulated under FMVSS/CMVSS 205 Glazing Materials.

Doors and flaps

If modifications need to be carried out to the load-bearing structure of the basic vehicle (crossmembers, frame, pillars, reinforcements, attachment of roof bows) in order to retrofit doors, the rigidity of the modified body must be equal to that of the basic vehicle.

- Seats must be accessible directly from the outside via a door or from the cab.
- It must be possible to open locked doors quickly and easily from the inside.
- The doors must open wide enough and the door entrances must be shaped in such a way as to

enable persons to get in and out of the vehicle safely and comfortably.

- The maximum permitted height of the bottom step above the roadway is 400 mm / 15.748 in.
- Fittings must allow sufficient clearance to the interior door handles regardless of the position of the sliding door to the load compartment (anti-pinch protection).
- On no account should modifications be made to the central locking system or to the immediate area around the door or in the area of the pillars or crossmembers.
- Once the upfit of the vehicle has been completed, please ensure that the interior of the door (e.g. door lock mechanism) is protected by a cover.

NOTE

Upon completion of all work on the vehicle, you must comply with the specified anti-corrosion protection measures (→ page 57).

Rear portal

NOTE

Any modifications to the rear door opening including the roof area are only permitted in exceptional cases and require a review from the responsible department through the Upfitter Portal. (→ page 12).

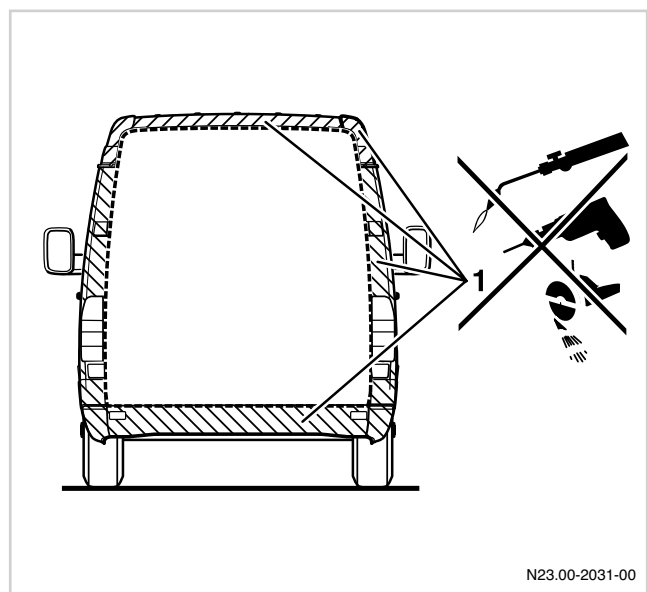

1 Rear portal area (UIS - Upfit Impact Study required)

6.2.4 Fenders and wheel wells

! NOTE

Lowering the wheel wells is not permissible. Otherwise, the vehicle could be damaged (e.g. wheel wells and tires).

6.2.5 Underfloor paneling

If modifications are made to the underfloor paneling which diminish the protection of vehicle underside against the weather, additional anti-corrosion protection measures are necessary on the entire substructure (example: sealing with underbody wax).

If trim parts are removed, this can cause wind noises.

6.2.6 Modifications to the roof structure

! NOTE

Modifications to the roof structure, including the rear portal, are only permissible in exceptional cases and an evaluation with the responsible department. As part of the ExpertUpfitter program please refer to www.UpfitterPortal.com (→ page 12).

⚠ WARNING

If aftermarket modifications are made to the headliner or the roof panel between the A-pillar and the B-pillar, the deployment of the window airbag may no longer function correctly.

If window airbags no longer function correctly, the occupants may be unprotected in the event of an accident. There is a risk of accident, personal injuries and death associated with such tampering and unauthorized installations!

On no account should any subsequent modifications be made to the headliner or the roof panel between the A-pillar and the B-pillar if the vehicle is equipped with window airbags.

- Roof bows or load-bearing parts may not be removed or damaged without being replaced.
- If a roof panel and roof bow are separated and if a continuous section frame is not possible, at least two additional roof bows in front of and behind the position of the removed bow are required.

- The bows must be secured to the side walls in such a way that a non-positive connection is guaranteed (bend-resistant connection of bows and roof frame).
- The maximum roof load must be observed.
- The maximum permissible center of gravity height must not be exceeded, see Chapter 4.1.2 Maximum permissible position of the center of gravity (→ page 47).
- When mounting a carrier system directly to the rivet nuts, only mounting supports approved by Mercedes-Benz or supports which correspond to drawings of Mercedes-Benz may be used as a direct connection to the roof. Other carrier systems may only be mounted on these. The load of 25 kg or 55.1 lbs per support foot and the maximum roof load must not be exceeded.
- The following body-specific notes on roof structure modifications must be adhered to.

Maximum roof load for standard roof

150 kg / 330.7 lbs

Location of roof bows

- Behind the front doors (B-pillar)
- At the center of the vehicle behind the sliding door to the load compartment (C-pillar)

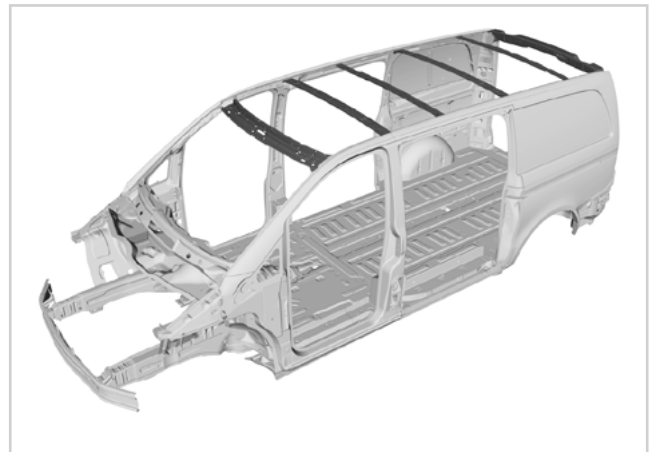

N65.20-2099-00

Isometric view of the roof bows

The strength of the new roof structure must correspond to that of the standard roof. The minimum moment of inertia required per roof bow is

$$I_x = 4000 \text{ mm}^4.$$

Roof cutouts

Roof cutouts must comply with the maximum values listed below.

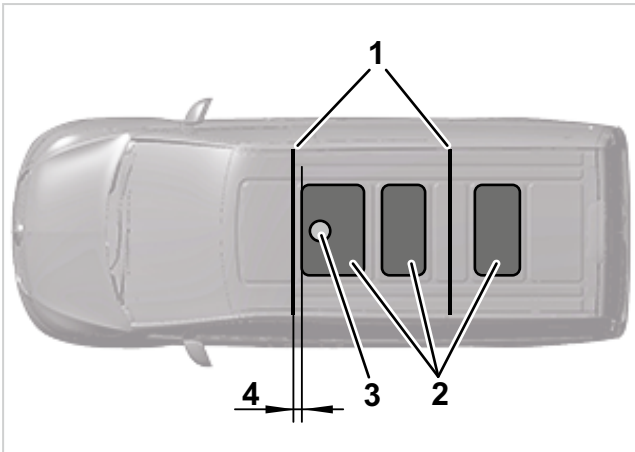

N65.00-2091-00

Roof cutouts based on example of 126" wheelbase vehicle

- 1 Roof bows
- 2 Possible positions for roof cutout
- 3 Max. roof cutout diameter 120 mm or 4.72 in
- 4 Min. clearance of 10 cm or 3.94 in from roof bows required

Roof height increase

The height of the roof may only be increased in conjunction with integrated bows and reinforcement frames.

Roof loads are not permissible when roof height extensions are fixed to the body.

Refer to Chapter 8.7.2 Crosswind Assist (→ page 112) for modifications to the projected lateral face.

Retrofitting a lifting roof/roof hatches

Plastic roofs are suitable for the installation of roof hatches only to a limited extent.

The roof load-bearing capacity is limited (→ page 52). In the event of deviations, evaluation is required from the department responsible (→ page 10).

If a lifting roof is fitted, at least two-thirds of the original roof area must be retained. Struts or load-bearing parts may not be removed.

Modifications to cab roof

⚠ WARNING

Modifications to the cab must not impair the function of any components relevant to safety (e.g. airbag units, sensors, pedals, gearshift lever, lines or others). This may lead to the failure of components or safety-relevant component parts.

On no account should subsequent modifications be made to the headliner or roof panel if the vehicle is equipped with window airbags. Otherwise, the window airbag may no longer work correctly (e.g. window airbag deployment is delayed or incomplete).

6.3 Engine peripherals/drivetrain

Modifications to the engine timing/performance enhancement

NOTE

Any interference in the engine timing by customers and upfitters is not permitted.

Manipulations or modifications to the engine timing cause changes in the certified engine data and emission values, and thus result in the immediate invalidation of the operating permit.

6.3.1 Fuel system

Modifications to the fuel system may only be carried out with the approval of the department responsible (→ page 10).

WARNING

Fuels are highly flammable. There is a risk of fire and explosion if fuels are improperly handled!

Avoid all fire, open flames, smoking and sparks.

NOTE

Non-approved modifications to the fuel system (fuel tank, lines, etc.) may lead to impaired performance and engine limp-home mode.

Note the following when working on the fuel system:

- The attachment of heat-conducting components or components which restrict installation space is not permitted.
- Modifications to the fuel pump, fuel line length and fuel line routing are not permitted. Any changes here to components that are matched to each other may impair engine operation.
- The clearance of the fuel filler neck, fuel tank and fuel lines must be maintained.
- For connections supplying fuel to an auxiliary heater, the procedure for type approval must be followed.

ENVIRONMENTAL NOTE

Modifications carried out incorrectly to the fuel system may have a detrimental effect on the environment.

6.3.2 Exhaust system

Mercedes-Benz AG recommends that no modifications be made to the exhaust system of Metris vans.

If modifications are made to the exhaust system, we recommend the use of Mercedes-Benz genuine parts.

Comply with all local and federal guidelines and regulations.

General

It is important to note that modifications to the geometry of the exhaust system and its piping are only permitted under the boundary conditions described below.

As part of such modifications, measurements of the exhaust gas back pressure must be taken (before/aer) to ensure that it has not increased in comparison to the unmodified exhaust system. The body manufacturer concerned must be able to provide evidence of these measurements to Mercedes-Benz AG on request.

All modifications above and beyond these constitute an alteration of a certified state in terms of emissions and noise levels.

Exhaust system geometry

The following dimensions must be observed when carrying out modifications on the exhaust system:

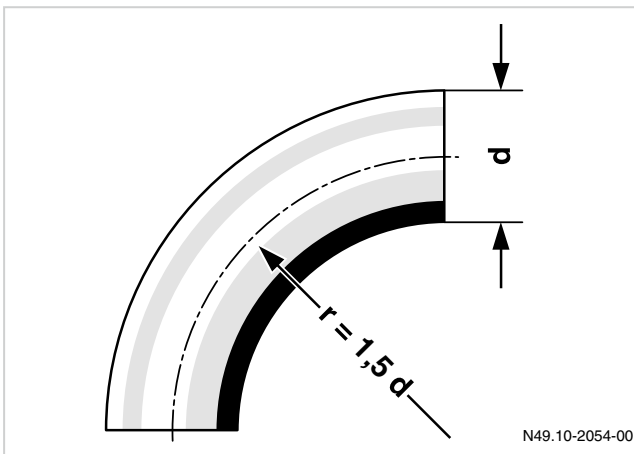

Example of a pipe bend design

- Maximum pipe bend 90°
- Avoid the use of additional pipe bends
- Bending radii >1.5 d

Minimum clearance to lines and detachable parts

When the vehicle is in operation, the temperature between the exhaust system (diesel particulate filter, catalytic converter or main muffler) and the floor panel may rise above 80°C / 176°F. During regeneration, the diesel particulate filter can reach a surface temperature in excess of 500°C / 932°F. Therefore, shielding or insulation must be mounted on the substructure to reduce the effects of radiated heat.

⚠ WARNING

If the minimum distance to fuel lines, plastic lines and electrical cables is not maintained, severe heat can result in a fire. There is a risk of fire and explosion!

Always comply with the specified minimum clearances.

Minimum clearances for fuel lines, plastic lines, electrical cables, and spare wheels, and for all components made of non-heat-resistant materials:

- 200 mm / 7.87 in mm for exhaust systems without shielding
- 80 mm / 3.15 in with sheet metal shielding
- 40 mm / 1.57 in with sheet metal shielding with additional insulation

It is important to not only consider the radiant heat emitted by the exhaust system, but also the jet of exhaust emitted behind the outlet under all operating conditions.

Additional shielding is required

- Near control panels
- Near major assemblies, attachments and equipment, unless they are made of heat-resistant material

! NOTE

Upon completion of all work on the vehicle, you must comply with the specified anti-corrosion protection measures (→ page 57).

6 Modifications to the basic vehicle

Exhaust emission

It must be ensured that the exhaust gases emitted from the tailpipe cannot enter the passenger compartment. Particular attention must be paid to this in the layout of accesses and doors.

Exhaust system

The length and installation position of the flexible metal hose (decoupling element) between the exhaust manifold and the exhaust pipe must not be modified.

The free cross-section of the exhaust pipe behind the main muffler must not be reduced and the overall vehicle acoustics (interior and exterior acoustics) must not be impaired by modifications to the exhaust system.

The schematic diagram below shows the area in which no modifications are permitted.

⚠ WARNING

The lengths and routings, e.g. between the particulate filter and the main muffler, are optimized with regards to temperature characteristics. Modifications could lead to higher or extreme temperatures in the exhaust system and surrounding components (propeller shafts, fuel tank, floor panel, etc.). There is a risk of fire!

Modifications to the exhaust system as far as the muffler are not permitted.

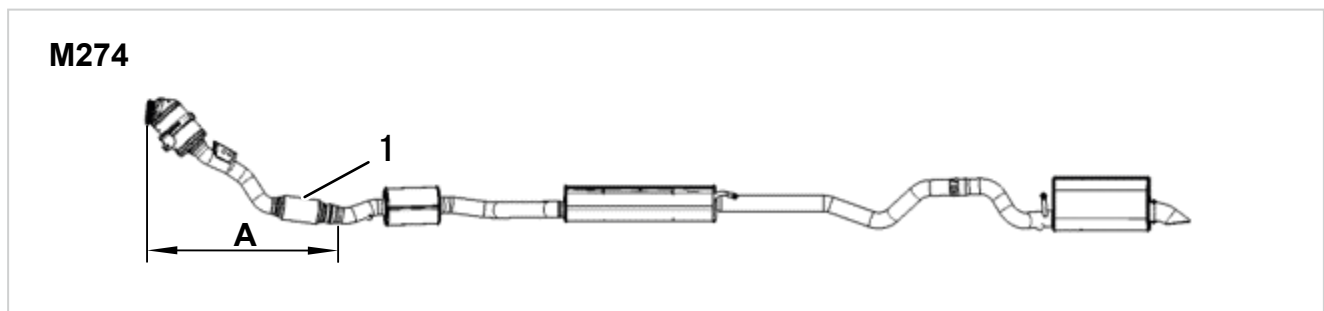

Schematic diagram of exhaust system – Area A, in which no modifications are permitted

- A Area in which modifications are not permitted
- 1 Decoupling element

6.3.3 Engine cooling

Modifications to the cooling system (radiator, radiator grille, air ducts, coolant circuit etc.) are not permitted. The cross-sectional areas of the cooling air intakes must be kept free (risk of engine limp-home mode).

Do not obstruct the radiator air inlet.

Do not affix warning signs, labels or decorative objects in the area in front of the radiator.

If required, flashing lamps at the front of the vehicle are to be mounted at the side of the radiator grille area (sealing of radiator section), on or between the horizontal fins. The vertical bars of the radiator grille may not be modified, as the stability of the radiator grille will otherwise no longer be guaranteed.

Additional cooling equipment for major assemblies shall be provided for cases where the vehicle is stationary and a high continuous output is demanded.

6.3.4 Intake air system

Modifications to the intake air system are not permissible.

The clean air side of the intake air system must not be modified in any way.

Warm air

- The intake of warm air will lead to a loss of engine power. A bulkhead between the intake point and the engine compartment is therefore essential.
- The intake temperature should not exceed the outside temperature by more than 10°C / 50°F.

Water

- Make sure that water cannot reach the intake points through any fresh air inlets. The flow velocity at the intake points must not be increased by modifications to the opening of the intake points.

Dust/dirt

- The area of the intake must be shielded against swirling dust from the wheel arch.
- Increased dust intake will lead to shorter maintenance intervals for the air filter.

6.3.5 Propeller shafts

! NOTE

On no account should modifications be made to the drivetrain.

6.4 Interior

6.4.1 General information

All relevant local and national regulations must be observed.

⚠ WARNING

Airbag and seat belt tensioner units are pyrotechnical objects. There is a risk of explosion when handling pyrotechnical objects. This can lead to personal injury.

Handling (installation, removal, transportation, storage and disposal) of airbags and seat belt tensioner units may therefore only be carried out by personnel who are appropriately qualified. Accident prevention regulations must be observed.

The handling, transportation and storage of pyrotechnical objects are subject to the hazardous materials law regulated by FMCSA under 49 CFR Part 173 in the U.S., and to the Transportation of Dangerous Goods Act (Transport Canada) in Canada. The purchase, transportation, storage, fitting, removal and disposal of potentially explosive substances may only be carried out by trained personnel and in accordance with the relevant safety regulations.

⚠ WARNING

Any modifications to restraint systems or their wiring could result in these restraint systems not functioning correctly. A restraint system can fail or unintentionally activate. There is a risk of injury!

Modifications to restraint systems or their wiring are therefore not permitted.

⚠ WARNING

If paint or surface treatment is applied to the instrument panel, the window airbags, the steering wheel impact absorber and the airbag tear seams, chemical reactions can occur on the treated surfaces. This could weaken or damage the materials meaning that the restraint systems no longer operate properly. There is a risk of injury!

Painting or surface treatment is not permissible on the instrument panel, the window airbags, the steering wheel impact absorber and the airbag tear seams.

Modifications in the cockpit area and above the belt trail line must fulfill the criteria associated with the head impact tests as per FMVSS 201.

This applies in particular to the deployment areas of the airbags (wooden trim, additional fittings, mobile phone cradles, bottle holders, etc.). See the illustrations of the airbag deployment areas for more information (→ page 77).

The permissible center of gravity and maximum permissible axle loads must not be exceeded.

Information on recreational vehicle conversions can be found under Chapter 7.4 Recreational vehicles (→ page 93).

- The interior must be designed with soft edges and surfaces.
- Fittings must be made of flame-resistant materials and be fitted securely.
- Unimpeded access to the seats must be ensured. There must not be any protruding parts, edges or corners which could cause injury in the area of the seats.

6.4.2 Safety equipment

⚠ WARNING

When the following alterations are made to the structure of the vehicle, the safe operation of restraint systems is no longer guaranteed:

- modifications to the seats
- modifications to the front-end assembly
- installation of parts in the vicinity of airbag inflation points or in airbag deployment areas. This also affects any installation of parts in the area of the instrument panel (cockpit) and A-pillar between the deployment area of the airbag and the front and side windows.
- installation of non-MB seats
- modifications to the A-pillar and B-pillar, the roof frame and its trim
- modifications to the doors

These modifications are therefore not permitted. This could otherwise result in personal injury.

! NOTE

Attachments with rigid connections to the front, side and rear of the vehicle at the height of possible accident zones could modify the characteristics of the vehicle's passive safety.

Seat belts

Vehicles must be equipped with seat belts. For seat belts, seat belt tensioners, and seat belt anchoring points, the relevant FMVSS/CMVSS regulations as well as any other local and national regulations must be complied with and verified. The anchoring of the seat belts must be tested as per FMVSS/CMVSS 210.

Airbags and seat belt tensioner units

All airbag units are labeled with the word "AIRBAG":

- The driver's airbag on the padded boss is recognizable by the inscribed word "AIRBAG".
- The front passenger airbag can also be recognized by the word "AIRBAG" inscribed on the dashboard paneling.
- The window airbags are identified by the "AIRBAG" inscription on the side of the headliner.
- The thorax/pelvis side airbag is marked with the inscription "AIRBAG" on the seat side seam facing the exterior of the vehicle.

An additional identifying feature is the red indicator lamp  on the instrument cluster.

Airbags installed in vehicle

The installed airbag units comprise the driver's airbag, front passenger airbag, window airbag and thorax/pelvis side airbag in the driver and front passenger seats.

- i** You can obtain further information on the airbags available as standard equipment and as special equipment from your Mercedes-Benz Service Center, from the department responsible "Advice for upfitters" (→ page 10) or under Chapter 3.10 Special equipment (→ page 44).

These components/assemblies may only be modified with the agreement of Upfitter Management Vans.

! NOTE

Modifications to the floor structure in the area of the airbag control unit are not permitted.

The following illustrations show the location and deployment areas (excluding dynamic travel) of the driver's airbag, the front passenger airbag, the window airbag and the thorax/pelvis side airbag.

It should be taken into account that deploying airbags require space for vibrations. For example, the front passenger airbag opens upwards towards the windshield, rests against it and then unfolds to either side and forwards towards the passenger.

6 Modifications to the basic vehicle

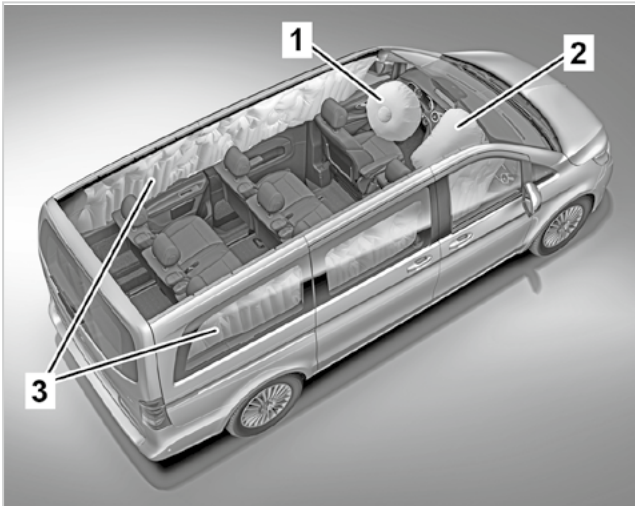

N91.60-2176-00

Airbag deployment areas on example of Metris passenger van with A-D window airbag (schematic diagram)

- 1 Driver's airbag (standard equipment)
- 2 Front passenger airbag
- 3 A-D Window airbag

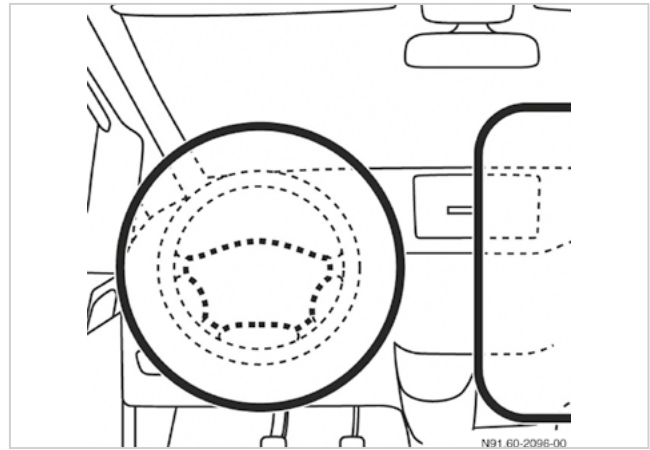

N91.60-2098-00

Driver's airbag deployment areas on example of Metris (standard equipment) (schematic diagram)

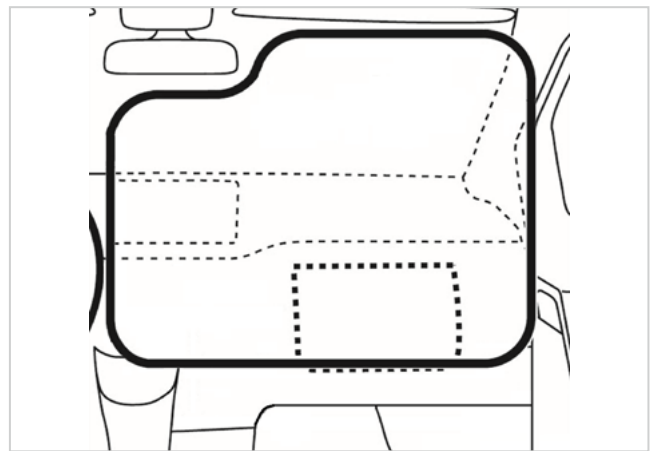

N91.00-2159-00

Front passenger airbag deployment areas on example of Metris (schematic diagram)

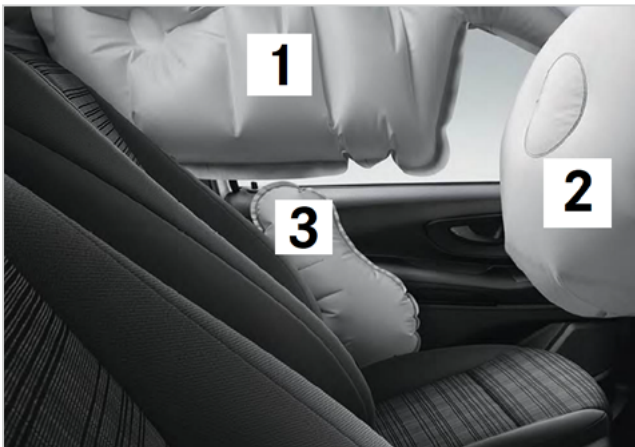

N91.60-2177-00

Airbag deployment areas on example of Metris (schematic diagram)

- 1 Window airbag
- 2 Driver's airbag (standard equipment)
- 3 Thorax/pelvis side airbag

Difference between A-B and A-D window airbags

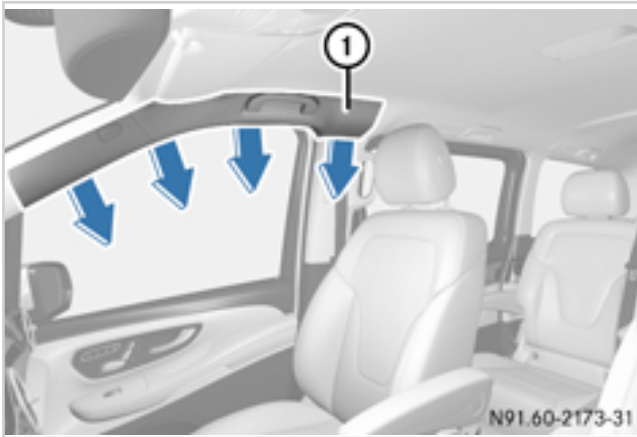

1 Deployment and coverage areas of A-B window airbag in the cargo vans for U.S./ Canada (schematic diagram)

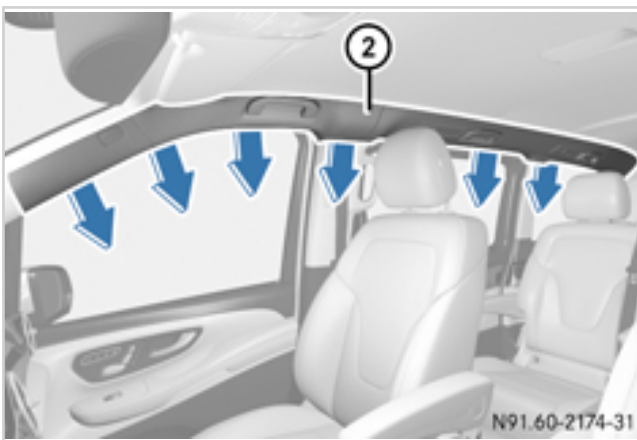

2 Deployment and coverage areas of A-D window airbag (schematic diagram)

⚠ WARNING

Any aftermarket installations to the interior of the Metris must not interfere with the deployment zone of the side curtain airbags. Partition wall may not be installed on a Metris passenger van.

For more information on locations where upfitter may not be installed, please refer to the Upfitter Portal technical bulletin: Airbag Deployment Zone Dimensions

Airbag control unit and side crash sensors, pressure sensors

It is not permitted to modify the standard installation location, installation position and attachment of airbag control units for occupant safety systems and side crash sensors on vehicles equipped with window airbags.

Other vehicle components may not be placed on or attached to the airbag control unit, the side crash sensors or their attachment points.

⚠ WARNING

Vehicle parts that generate vibrations may not be mounted in the proximity of the airbag control unit or the sensor installation locations. Nor may modifications be made to the floor structure in the proximity of the airbag control unit or the satellite sensors. Reliable operation of the front airbag, window airbag and thorax/pelvis side airbag and seat belt tensioners is otherwise no longer guaranteed and there is consequently a risk of injury.

The position of the airbag control unit, triggering sensors and ESP® turn rate sensor is in the footwell/ center console behind the trim.

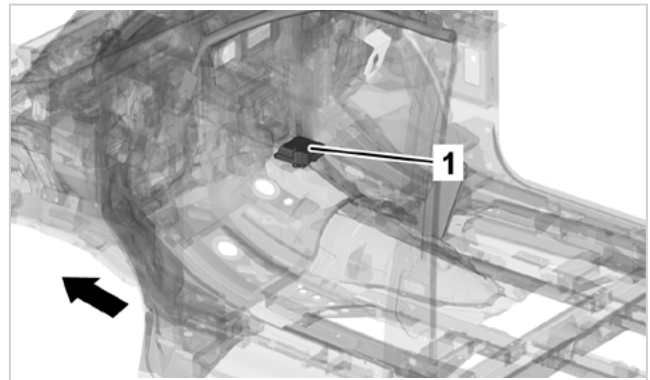

1 ESP® with integrated sensor cluster
Arrow Direction of travel

A removed airbag control unit is susceptible to shock and must be stored in an area free of vibrations.

⚠ WARNING

Airbag sensor systems, ESP® turn rate sensors or airbag control units that have fallen to the ground may not be installed due to safety reasons. These parts must be replaced with the corresponding Mercedes-Benz genuine parts. Otherwise proper and safe functioning of these systems cannot be ensured and this could result in personal injury.

The side crash sensors are located in the lower area of the B-pillar behind the trim on both sides (same as on left side of vehicle).

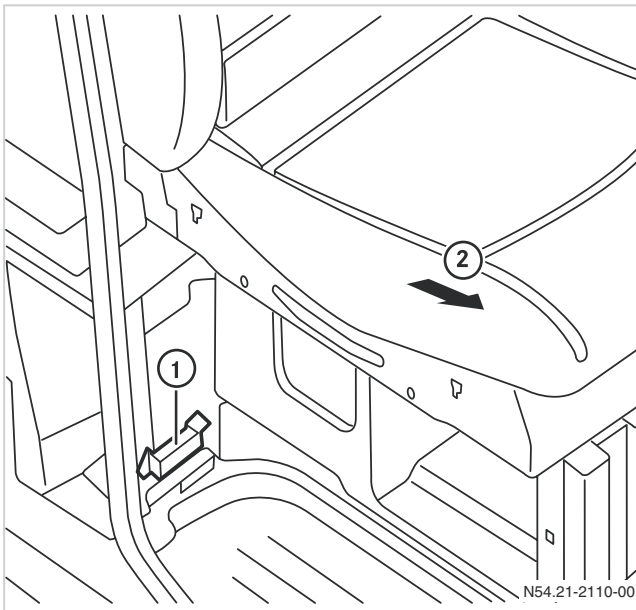

- 1 Side crash sensor
- 2 Direction of travel

Handling airbag and seat belt tensioner units

⚠ WARNING

Removed airbag units must always be stored in such a way that the padded side faces upwards. If the padded side faces downwards, the airbag unit will be catapulted through the air if it is triggered accidentally. This can lead to personal injury.

Testing and installation work may only be carried out and/or supervised by trained personnel.

Airbag and seat belt tensioner units may only be subjected to electrical tests using the specified test equipment when installed. We recommend that tests be carried out at a Mercedes-Benz Service Center.

The assembly and disassembly of airbag and seat belt tensioner units may only be carried out when the battery is disconnected, the negative terminal or negative pole is covered up and the test coupling/connector is disconnected.

Airbag and seat belt tensioner units may only be removed from storage immediately before assembly. After disassembly, airbag and seat belt tensioner units must be put into storage immediately.

If work is interrupted, the airbag and seat belt tensioner units must be locked away again.

Airbag and seat belt tensioner units may not be treated with grease, cleaning agents or other similar products.

The airbag and seat belt tensioner units may not be exposed to temperatures above 100°C / 212°F, even for a short period of time.

Airbag and seat belt tensioner units must be replaced if they are dropped from a height of more than 0.5 m / 19.685 in.

Transporting and storing airbag units and seat belt tensioner units

Transporting pyrotechnical airbag units and seat belt tensioner units in the passenger compartment is not permitted.

Transportation should always be carried out using the replacement part packaging and utilizing the vehicle trunk or load compartment.

⚠ WARNING

Removed airbag units must always be stored in such a way that the padded side faces upwards. If the padded side faces downwards, the airbag unit will be catapulted through the air if it is triggered accidentally. This can lead to personal injury.

Class T1 pyrotechnical materials may only be stored in limited quantities on premises used for commercial purposes.

The handling, transportation, and storage of airbag units are subject to the hazardous materials law regulated by FMCSA under 49 CFR Part 173 in the U.S., and to the Transportation of Dangerous Goods Act (Transport Canada) in Canada.

Gross mass of pyrotechnical components in the Metris

	[kg]	[lbs]
Driver's airbag	1.14	2.51 lb
Front passenger airbag	2.82	6.22 lb
A-B Window airbag	1.12	2.47 lb
A-D Window airbag	3.98	8.77 lb
Thorax/pelvis side airbag	0.43	0.95 lb
Seat belt	1.3	2.87 lb

Disposing of airbag and seat belt tensioner units

Pyrotechnical airbag and seat belt tensioner units must be disposed of in accordance with country-specific laws and directives.

These safety measures are necessary because pyrotechnical materials could cause injury if activated incorrectly.

Hazards arise from disposal using cutting torches, by smelting, or if primed parts are disposed of on open fires or smoldering fires on waste disposal sites.

We recommend having disposal of the pyrotechnical objects carried out by a waste disposal company who can satisfy the required safety measures (e.g. 10 m or 32.8 ft safe distance, special ignition equipment).

When the materials are handed over, the waste disposal company must sign a declaration containing the obligation to dispose of the pyrotechnical materials in accordance with accident prevention regulations. Agreements of this kind must ensure that it is not possible to extract pyrotechnical materials after disposal and to pass them on for repairs.

- If seat belt tensioners that have not been triggered require detonation for disposal purposes, place them in the footwell of a vehicle which has been sent for scrapping, and connect them directly using a 2-pin connector coupling.
- If the upholstery pads on the airbag units have not been destroyed, the airbag units must be detonated by trained personnel using the 2-pin connector coupling.

6.4.3 Seats

If seats other than those fitted at the factory are desired to be used, please contact the Upfitter Management Vans/ Upfitter Portal. As part of the Expert-Upfitter Program, possible deviations can be evaluated with the responsible department.

Proof of the strength of the seats delivered from the factory is only valid if the seats are secured in original mountings. Any deviation must be coordinated with the department responsible “Technical advice on body compatibility” (→ page 10).

A rear seat system with 2- or 3-point seat belts that deviates from the standard seating arrangement must meet the requirements of the FMVSS/CMVSS 207 (seating systems) and the FMVSS/CMVSS 210 (seat belt assembly anchorages) standard. Furthermore, the standard FMVSS/CMVSS 209 (Seat belt assemblies) must be adhered to. For the headrests, proof of compliance with the FMVSS 202a/CMVSS 202 (Head restraints) standard is required.

Seats without belts are not permitted.

When seat belts and seats (including seat bases) are reinstalled, new bolts must be tightened to the specified torque.

In addition, to safeguard against production variations and measurement tolerances, the following must be taken into account or verified when testing the seats:

- A suitable method (s.g. statistical methods such as Six Sigma)

or

- Failure-free completion of the belt anchoring test at a test force of 120% of the values specified in the standards

Upfitter Management Vans reserves the right to request these test certificates at any time as part of its product monitoring activities.

Test certificates for seats on a rigid plate will not be accepted.

When seat belts and seats (including seat bases) are reinstalled, the specified bolts must be tightened to the specified torque.

WARNING

Unsuitable seat covers could hinder, or even prevent, the deployment of the airbags integrated in the seats. The airbags would then not protect the vehicle occupants as intended. There is a heightened risk of injury or even of death!

Only use seat covers approved by Mercedes-Benz for the seat in question.

- ① Information on retrofitting seats can be found in Chapter 7 Design of bodies (→ page 91).

6.4.4 Reducing interior noise

Soundproofing material can be installed in order to reduce the noise level in the vehicle interior. It must be barely inflammable.

Floor area

A structure as shown in the illustration is advisable for insulation and soundproofing. An additional covering with heavy-duty insulating foil may be provided in the area of the wheel wells.

NOTE

Insulating foils, e.g. bituminous felt, have limited temperature resistance. They should therefore not be installed in the immediate vicinity of the engine or exhaust system.

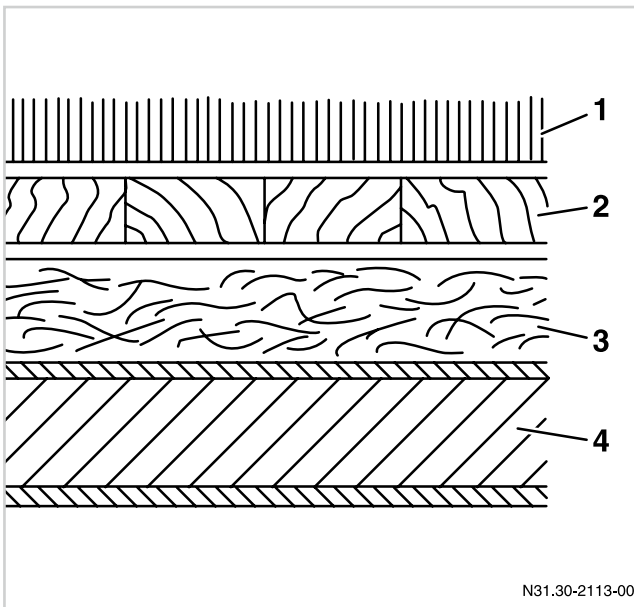

- 1 Carpet (rubberized underside)
- 2 Wooden floor (12 mm or 0.47 in plywood)
- 3 Heavy-duty insulating foil (weight per unit area 8-10 kg/m₂ or 1.64-2.05 lb/ft₂)
- 4 Load-bearing construction

Roof and side walls

Apart from providing insulation, the materials used for insulation should exhibit the following properties:

- Not hygroscopic
- Not water-retaining
- Not water-absorbing
- Not water-attracting
- Water-repellent

Arrangements are to be made for the rapid and unhindered drainage of accumulated moisture or condensation in order to avoid conditions that promote corrosion.

The standard drain holes must be preserved intact. If necessary, additional drain holes must be created after consultation with the relevant department "Technical advice on body compatibility" (→ page 10).

The inside must be covered with a sound-transmitting material (e.g. perforated card, plastic, fabric cover).

WARNING

On no account should subsequent modifications be made to the headliner or roof panel if the vehicle is equipped with window airbags. Otherwise, the window airbag may no longer work correctly (e.g. window airbag deployment is delayed or incomplete).

Seals

Openings, gaps and slots between the engine compartment or the vehicle underside or the firewall and the vehicle interior must be carefully sealed with elastic material. Vent openings must not be fitted in the immediate vicinity of sources of noise.

In addition, manufacturers or suppliers of soundproofing materials should be consulted. They will be able to provide you with suggestions on how to design optimum noise insulation for your modified vehicle body.

6.4.5 Ventilation

The living compartment and the driver area must have adequate ventilation with provision for air to enter and exit.

The windshield and side window demisting function must remain operational, especially if the driver's area forms part of the passenger compartment or if the layout and design of the interior does not correspond to that of the standard equipment.

i New vehicles can be delivered with various heating/ventilation options and air conditioning systems as special equipment. Additional information on special equipment can be obtained from your Mercedes-Benz Service Center, from the relevant department (→ page 10) or under Chapter 3.10 Special equipment (→ page 44).

6.5 Additional assemblies

The notes in Chapter 5.3 Anti-corrosion protection measures (→ page 57) and Chapter 5.4 Painting work/preservation work (→ page 59) must be observed.

6.5.1 Auxiliary heating

The floor of the vehicle must be airtight if exhaust gases are routed out under the vehicle.

Openings in the vehicle floor provided for control elements must be sealed with rubber sleeves.

Retrofitting auxiliary heating

When retrofitting an auxiliary heating system, the specifications for fire protection, impact performance and accident protection must be observed. The danger of poisoning or suffocation due to gaseous substances must be prevented through the selection of the installation location or through appropriate sealing measures.

The following components of the auxiliary heating may not be mounted within the cab, the passenger compartment or load compartment:

- Auxiliary heating
- Exhaust pipes of the auxiliary heating
- Vents for components of the auxiliary heating system
- Fuel lines
- Fuel tank and tank filler neck

All pipes, hoses and electric lines should be routed so that they are free of mechanical stress.

i Before installing auxiliary/stationary heaters, please contact the Upfitter Management Vans team (→ page 10).

i Additional information can be found under Chapter 3.10 Special equipment (→ page 44).

6.6 Attachments

For attachments to the frame, an evaluation with the responsible department is necessary. As part of the ExpertUpfitter program please refer to www.UpfitterPortal.com.

The permissible center of gravity locations and axle loads must always be adhered to, see Chapter 4 Technical limit values for planning (→ page 47).

Note that this may interfere with driving assistance systems, see Chapter 8.7 Driving assistance systems (→ page 110).

Attachments must not impair the function of vehicle parts.

Comply with local and federal legal requirements.

6.6.1 Attachment above cab

- The permissible center of gravity height, see Chapter 4.1 Limit values for the basic vehicle (→ page 47), and front axle load, see Chapter 4.2 Limit values for the suspension (→ page 50), must be observed.
- The roof connection must be designed as per Chapter 6.2.6 Modifications to the roof structure (→ page 70).

6.6.2 Roof luggage racks

- Make sure that the load is distributed evenly across the entire roof area.
- Installation of a stabilizer bar on the front axle is recommended.
- Support feet must be spaced at regular intervals. The load per support foot may not exceed 25 kg / 55.12 lbs.
- With shorter roof luggage racks, the load must be reduced proportionally.

Roof luggage rack limit values

	Max. roof loads	Minimum no. of support feet
Normal roof	150 kg / 330.7 lbs	6

6.6.3 Shelf systems

General

Shelf systems must

- Be sufficiently strong and self-supporting.
- Rest on the crossmembers and longitudinal members of the vehicle floor.
- Equally distribute all forces and loads.
- Shelf system must be installed tension-free.

The application of force must take place through the floor attachments.

The shelving must be supported by the fastening points on the vehicle side wall.

Shelf systems must not collapse in the event of a crash. Shelf systems must have no negative influences on the base model vehicle and its functions (passive safety in particular).

Please also observe the notes in Chapter 4.1 Limit values for the basic vehicle (→ page 47).

! NOTE

On no account should attachments transfer forces only to the vehicle side walls. Point loads must not be applied to the vehicle wall.

Otherwise there is a risk of damage to the side wall.

We recommend the special equipment available for panel vans "Tie-down rails, side wall to belt rail" (code V42) for supporting shelving and workshop installations.

Stability

The stability of the shelf system must be ensured by mounting it to the vehicle floor and supporting it at the vehicle side wall. We recommend reinforcing the shelf construction with diagonal struts.

In order to test shelf constructions with respect to their stability and installation in the vehicle, we recommend that upfitters commission an authorized testing institute to carry out the appropriate testing.

Load rails ex factory

The following load rails in the vehicle are available as special equipment ex factory for cargo vans:

- Code V42 Tie-down rails, side wall to belt rail (underneath the stamped window shape, for supporting shelving)
- Code VV2 Load retainer rail system for floor mounting

Maximum tensile forces of genuine Mercedes-Benz load rails (permissible rated tensile force)

Maximum load forces

Code V42	Tie-down rails, side wall to belt rail ¹	100 daN / 225 lbf
Code VV2	Load retainer rail system for floor mounting ¹	500 daN / 1,124 lbf

1 Connection to vehicle side wall by threaded connection

The stated values only apply if the following conditions are met:

- The load must be secured by at least two tie-down points on the rail.
- The distance to the next load securing point on the same rail may be max. 1 m / 39.37 in.
- The load must stand on and be fixed in place at the floor.

Windows

- The installation of windows within the area of fitted shelving is not recommended.
- A cargo van is recommended as the basic vehicle. Shelf systems should only be installed in the area of the unglazed side wall.

Partition wall

Please also observe the notes in Chapter 6.2.2 ISO conformity of partition (→ page 67).

Safety equipment

The installation locations of safety equipment and airbag deployment areas must not be constrained or modified. Please observe the notes in Chapter 6.4.2 Safety equipment (→ page 77).

Electrics/electronics

- Please observe the specifications as per Chapter 8 Electrics/electronics (→ page 95) when installing electrical or electronic equipment and/or consumers in combination with shelving or workshop installations.
- The cable routing for the interior lighting or for the trailer coupling in the roof or in the D-pillar may not be impaired.

! NOTE

Shelving or workshop installations reduce the available payload by the weight of the installation!

Upfitter Management Vans therefore recommends displaying the remaining payload including the shelf system to the end customer (e.g. with a dedicated identification plate).

In addition, Upfitter Management Vans recommends displaying to the end customer the maximum permissible shelf load and the maximum permissible shelf unit load (e.g. by means of an information label/additional operating instructions).

Drilling in the floor

Pay attention to the following when drilling the floor of the body:

- Drilling is not permitted in the area of the cable duct which runs longitudinally along the center of the vehicle floor.
- The holes must be positioned away from the edge area/line of tendency of the ribbing.



N68.00-3027-00

Cable duct based example of vehicle floor with body length A2

Drilling areas

⚠ WARNING

Drilling in the area of safety-relevant components (e.g. fuel tanks or lines, electrical wiring, brake hoses, brake cables etc.) can cause these components to no longer function correctly. This may lead to the failure of components or safety-relevant component parts. This could cause the driver to lose control of the vehicle. There is a risk of accident, personal injuries, and death!

Gasoline vapors can easily ignite due to the heat produced when drilling. There is a risk of fire and explosion when drilling into components containing fuel!

Before every drilling operation, make sure that there are no components, and in particular no safety-relevant components, behind the part to be drilled, which could be damaged by the drill bit.

6 Modifications to the basic vehicle

Anti-corrosion protection measures

To ensure compliance with the anti-corrosion warranty of the vehicle manufacturer, upfitters must observe important anti-corrosion protection measures after drilling through the body.

Whenever an assembly hole is made in the vehicle body, one or more elements of the existing protection system is/are irreparably damaged.

The upfitter making the modification is therefore obliged to restore the quality of the corrosion protection system to that of the basic vehicle.

Upon completion of all work on the vehicle, the notes given in Chapter 5.3 Anti-corrosion protection measures (→ page 57) must be observed.

Attachment points for shelving or workshop installations

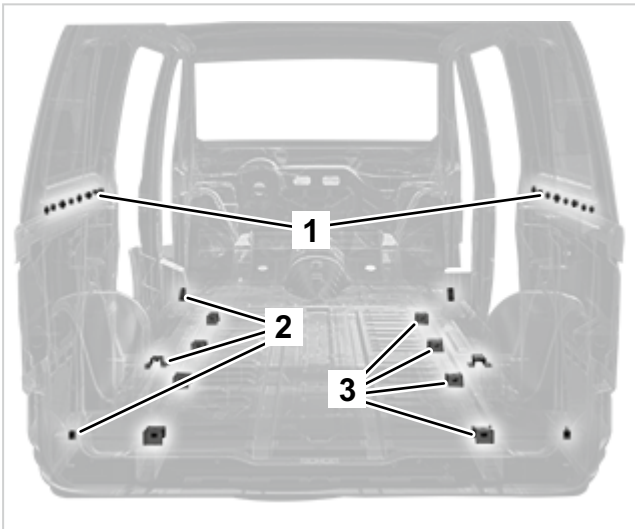

N68.00-3028-00

Existing attachment points in body floor and belt rail

- 1 Attachment of side wall tie-down rail to belt rail (code V42)
- 2 Tie-down eye attachment
- 3 Load retainer rail system attachment (code VV2)

Bolting shelving or workshop installations to the floor

There are various methods for bolting the shelving to the floor depending on the requirements:

- Bolting it to a special mounting floor, which is bonded to the vehicle floor over its entire area or bolted to the existing attachment points of the vehicle floor or which combines the two aforementioned fastening types.
- Drilling through the body floor so that the structure is bolted on through both the mounting floor and the vehicle floor panel.
- High-rib/low-rib connection: Spacer sleeves are required when connecting to a low rib.

Mounting floor for shelving or workshop installations

The base should be a mounting floor, which is bolted on through the existing bores and threads in the vehicle floor. It is also permissible to attach it using a suitable adhesive over its entire area or to combine the two aforementioned fastening types.

We recommend anti-slip, pressure-resistant, oil/water/acid-resistant floors for shelving or workshop installations. The quality of the mounting floor should be at least equal to the wooden floor supplied ex-factory.

Bolting through the floor panel

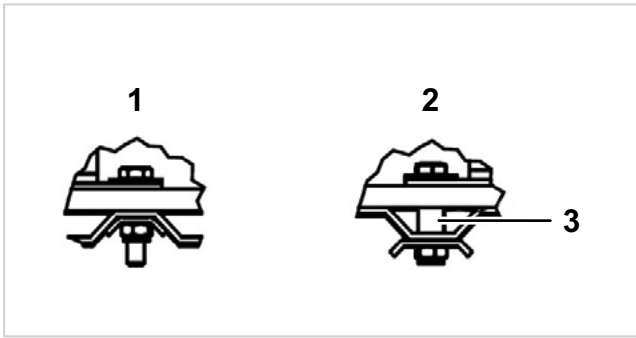

N68.00-3029-00

Connection on high and low rib

- 1 High rib
- 2 Low rib
- 3 Spacer sleeve for equalizing the low rib

Maximum loading of tie-down eyes (vehicle floor)

Tie-down eyes	Maximum rated tensile force
Passenger	350 daN / 787 lbf
Cargo van	500 daN / 1,124 lbf

Recommended adhesives for mounting floor:

High-strength adhesive

e.g. XW-1044 from Dow Automotive or an adhesive of equal quality

! NOTE

The handling instructions and shelf life specification of the adhesive manufacturer must be followed. If the manufacturer specifications are not followed, the adhesive may not achieve the required properties.

Support adhesive

e.g. Terostat 3112 from Henkel or an adhesive of equal quality

Side wall/belt rail connection

Further connecting points have to be chosen to secure the structure depending on the size/weight of the installation. If the installation height surpasses the belt rail, we recommend an additional connecting point at the end of the shelf unit on the C or D-pillar. Further connecting points have to be chosen to secure the structure depending on the size/weight of the installation.

It is the responsibility of the upfitter to provide a substitute of equal quality to code V42 "Tie-down rails, side wall to belt rail" when retrofitting shelving or a workshop installation.

The tie-down rails must be connected to the belt rail by bolting. All of the bores (for M8 bolted connections) provided as standard in the belt rail profile must be used to connect the tie-down rails to the belt rail over the length of the tie-down rail. Depending on the as-built configuration of the vehicle, reinforcements may be needed in the belt rail profile.

The weld nuts in the side wall, which are required by the upfitter for interior fittings, can be ordered under the code VV0 (Side wall weld nuts for fittings).

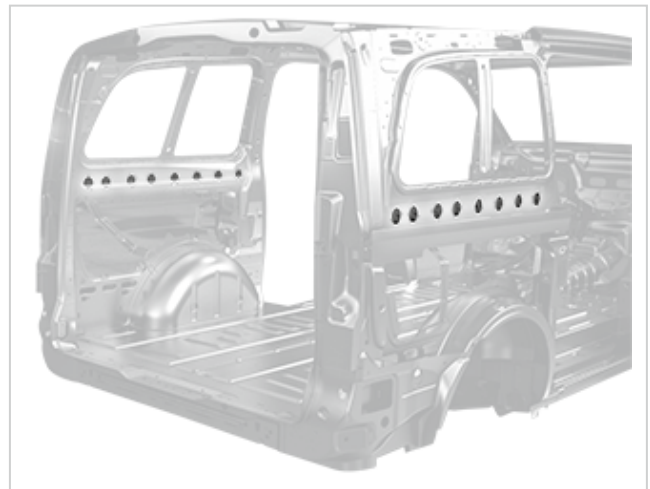

N68.00-3030-00

Belt rail attachment points based on example of A2

Additional information is available from the department of the Upfitter Portal (→ page 12).

Retrofitting "Tie-down rails, side wall to belt rail" (as per code V42)

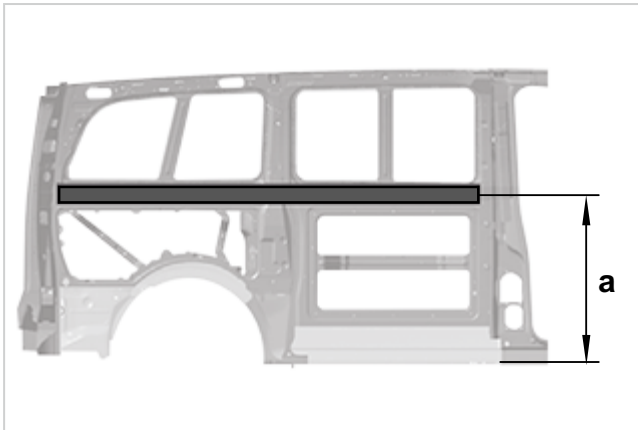

N68.00-3031-00

Position of retrofitted "Tie-down rails, side wall to belt rail"

Position of tie-down rail

Center tie-down rail	Dimensions
Based on standard wooden floor	a = 677 mm = 26.65 in
Based on vehicle floor (upper ribbing)	a = 687 mm = 27.05 in

The following points must be observed when retrofitting "Tie-down rails, side wall to belt rail":

- The instructions of the tie-down rail manufacturer must be observed. We recommend the Mercedes-Benz parts kit for retrofitting the "Tie-down rails, side wall to belt rail" (as with code V42).
- The maximum tensile force (see "Stability" (→ page 86)) must be clearly indicated in the area of the tie-down rails (e.g. using adhesive labels) and must also be indicated in the operator's manual in the vehicle.
- All the holes in the bodyshell profile of the belt rail must be used to bolt on the tie-down rails.

! NOTE

Retrofitting "Tie-down rails, side wall to belt rail" may only be carried out in the areas of the vehicle side wall intended for this purpose in the same way as for code V42.

The maximum tensile force specification (see notes under "Stability") must be complied with under all driving conditions.

Otherwise there is a risk of damage to the side wall.

6.6.4 Trailer coupling

We recommend only using trailer couplings approved by Mercedes-Benz or of equal reliability. These should only be attached at the intended points on the body-shell (rear longitudinal member).

- Access to the spare wheel must be guaranteed if a trailer coupling with a non-detachable ball head is fitted (especially with a fully laden vehicle).
- The trailer coupling attachment must comply with all the respective local and national regulations
- The country-specific clearance dimensions must be taken into account.

Technically, there is no problem retrofitting a trailer coupling when a pre-installation (Code E 57) is already fitted.

If a trailer control unit was not pre-installed at the factory, it must be installed and connected in addition to the retrofitted cable set. In addition, variant coding of the electronic ignition lock must be performed otherwise malfunctions could occur. Variant coding is performed using a Mercedes-Benz diagnostic device. We recommend having the variant coding performed at a Mercedes-Benz Service Center.

7.1 Modifications to the interior

This chapter contains information concerning the body to be produced by the upfitter.

7.1.1 Modifications in the cockpit area

Modifications in the cockpit area and above the beltline are not permitted. This applies in particular to the deployment areas of the airbags (wooden trim, additional fittings, cell phone holders, bottle holders etc.)

See the illustrations of the airbag deployment areas for more information (→ page 77).

7.1.2 Retrofitting seats

Proof of the strength of the seats delivered from the factory is only valid if the seats are secured in original mountings.

For modifications to the seat attachments (including seat bases) and seat belt anchorages or for the installation of seats other than those available from the factory, an evaluation with the responsible department is necessary. As part of the ExpertUpfitter program please refer to www.UpfitterPortal.com.

When retrofitting seats, it is absolutely essential to keep to the H-point. You can obtain up-to-date documentation from the department responsible (→ page 10).

When reinstalling seat belts, the specified bolts must be tightened to the original torque.

⚠ WARNING

It is not permitted to modify the driver and front passenger seats or to mount seats on the wheel wells. In the event of an accident, the seats could become detached from their mountings.

Passengers cannot be protected as intended. There is a risk of injury!

⚠ WARNING

If seats are mounted on the wheel well, they could be torn from their anchorages in the event of an accident. There is a risk of injury!

Therefore do not mount any seats on the wheel well.

If seats with 2 or 3-point seat belts or a rear bench seat with 2 or 3-point seat belts deviate from the standard seating arrangement must meet the requirements of the FMVSS/CMVSS 207 (seating systems) and the FMVSS/CMVSS 210 (seat belt assembly anchorages) standard. Furthermore, the standard FMVSS/CMVSS 209 (Seat belt assemblies) must be adhered to. For the headrests, proof of compliance with the FMVSS 202a/CMVSS 202 (Head restraints) standard is required.

Seats without belts are not permitted.

When seat belts and seats (including seat bases) are reinstalled, new bolts must be tightened to the specified torque.

⚠ WARNING

Unsuitable seat covers could hinder, or even prevent, the deployment of the airbags integrated in the seats. The airbags would then not protect the vehicle occupants as intended. There is a heightened risk of injury or even of death!

Only use seat covers approved by Mercedes-Benz for the seat in question.

- i** Additional information on special equipment can be obtained from your Mercedes-Benz Service Center, from the relevant department (→ page 10) or from Chapter 3.10 Special equipment (→ page 44).

Roof

Information on roof modifications can be found under Chapter 6.2.6 Modifications to the roof structure (→ page 70).

7.2 Refrigerated vehicles/temperature-controlled vehicles

Refer to the following chapters:

- Chapter 6.2.6 Modifications to the roof structure (→ page 70)
- Chapter 6.4.4 Reducing interior noise (→ page 83)
- Chapter 8.4.4 Connecting additional electrical consumers (→ page 101)

These requirements and notes are also applicable for vehicles used to transport loads under constant conditions within the load compartment, for example with a constant temperature higher than 0°C / 32°F.

! NOTE

When refrigeration systems or components are used in combination with R1234yf (only available in Canada), all application local and federal laws, specifications, and safety regulations must be observed.

In particular, compliance with the safety regulations according to ISO 13043 at both the component and overall system level (FMEA, leak-tightness requirements, concentration measurements, etc.) must be guaranteed.

In addition, it must be ensured that the safety requirements regarding inflammability and the risk of combustion associated with R1234yf are observed (best possible packaging and greatest possible distance from hot parts and installation of additional facilities, if necessary, to ensure that required level of safety).

If R1234yf is used, a specific information label with details of the quantity and combustion risk must be considered or installed in a visible location.

7.3 Vehicles for transportation of technical gases

Tanks and lines for liquefied gases must be equipped with adequate heat insulation from the rest of the vehicle. This is even more important for lines that are passed through the vehicle chassis or the body-in-white.

To allow venting of supercooled liquefied gases, a minimum distance of at least 3 m / 118 in is required between the vent opening and the vehicle. If venting is necessary, make sure that the vent opening points away from the vehicle.

Any escaping condensation must be caught in a suitable container.

Transport of gases is subject to the hazardous materials law regulated by FMCSA under 49 CFR Part 173 in the U.S. and to the Transportation of Dangerous Goods Act (Transport Canada) in Canada.

7.4 Recreational vehicles

General

Prior to conversion into a recreational vehicle, please note:

- All national and local legal requirements must be complied with.
- The legal requirements for interior design and equipment for recreational vehicles must be fulfilled.
- Permissible center of gravity position and axle loads

Information on registration eligibility of recreational vehicles”

Particular attention must be paid to the following sections of the Body and Equipment Guideline:

- Chapter 3.3 Dimensions and weights (→ page 30).
- Chapter 6 Modifications to the basic vehicle (→ page 61)
- Chapter 6.1.5 Wheels/tires (→ page 64)
- Chapter 6.2.4 Fenders and wheel wells (→ page 70)
- Chapter 6.4.2 Safety equipment (→ page 77)
- Chapter 7.1.2 Retrofitting seats (→ page 91)
- Chapter 8 Electrics/electronics (→ page 95)
- Chapter 8.7 Driving assistance systems (→ page 110)

Modifications or conversions to standard vehicles (e.g. the installation of a lifting roof) may invalidate the operating permit. Please refer to country and/or state-specific legal regulations. For the U.S. operating permits, the approval conditions and requirements of the Department of Motor Vehicles (DMV) must be met. For Canadian operating permits, please refer to provincial transportation ministries. The upfitter must ensure that the vehicle has complete operating approval.

Any aftermarket installations to the interior of the Metris must not interfere with the deployment zone of the side curtain airbags.

The interior fittings must be designed in such a way that there are no sharp edges or corners (accident prevention).

Fittings must be made of flame-resistant materials and be fitted securely. Unimpeded access to the seats must be ensured. There must not be any protruding parts, edges or corners which could cause injury in the area of the seats.

7.5 Retrofitting a pop top roof

Observe the information under Chapter 6.2.6 Modifications to the roof structure (→ page 70) and Chapter 6.4.2 Safety equipment (→ page 77) for retrofitting pop top roof.

Ensure that no aftermarket installation interferes with the airbag deployment zones including the side curtain airbag deployment zone. Furthermore, all relevant FMVSS/CMVSS regulations including FMVSS 201 must be complied and tested. Note that all other relevant local and national regulations must also be adhered to.

7.6 Roof height increase

For an aftermarket increase in the height of the vehicle roof, refer to the information under Chapter 6.2.6 Modifications to the roof structure (→ page 70).

7.7 Government vehicles

The following sections of the Body and Equipment Guideline must be observed:

- Chapter 3.3 Dimensions and weights (→ page 30)
- Chapter 6 Modifications to the basic vehicle (→ page 61)
- Chapter 6.3.3 Engine cooling (→ page 75)
- Chapter 8.2 Electromagnetic compatibility (EMC) (→ page 96)
- Chapter 8.4.4 Connecting additional electrical consumers (→ page 101)

Recommended special equipment (codes) for conversion to a government vehicle

- Code ED5: PSM (MPM) (Parameterizable special module)

i You can obtain further information on recommended special equipment from the responsible department (→ page 10).

8.1 General information

⚠ WARNING

Modifications to electronic components, their software or wiring can impair their functioning and/or the functioning of other networked components. Safety-relevant systems in particular may also be affected. Because of this, they may no longer function properly and/or compromise the operational safety of the vehicle.

There is a heightened risk of accident and injury! Never carry out any modifications to the wiring and electronic components or their software. Have all work on electrical and electronic equipment carried out at a qualified specialist workshop.

! NOTE

When connecting additional electrical consumers (→ page 101), a positive total charge balance must be ensured.

Do not release or remove the battery terminals when the engine is running.

Rapid-charge the batteries only after disconnecting them from the vehicle's electrical system. Both the positive and negative terminals must be disconnected.

! NOTE

The upfitter is responsible for functional safety of the body mounting work performed by him or her with observance of the applicable standard and regulations. Furthermore, the upfitter must guarantee compliance with the international standard ISO 26262 concerning functional safety, if applicable. Please also refer to 49 CFR 567.5 in the U.S. and to Motor Vehicle Safety Regulation 6(1)-6(7) in Canada for requirements for manufacturers of vehicles manufactured in two or more stages.

- Electrical and electronic components must fulfill the test requirements of ISO 16750.
- Observe the notes (→ page 97) when installing auxiliary batteries.
- Cables routed in the vicinity of exhaust systems must be insulated against high temperatures, see Chapter 5.1 Brake hoses/cables and lines (→ page 54).
- Cables must be routed in such a way that there are no chafe marks, see Chapter 5.1 Brake hoses/cables and lines (→ page 54).
- If the vehicle is to be left non-operational for more than a week, the battery must be disconnected. The batteries must have a sufficient state of charge when the vehicle is put into operation again (→ page 97).
- Observe the operator's manual.

8.2 Electromagnetic compatibility (EMC)

Electromagnetic compatibility describes the ability of an electrical system to act neutrally in the vicinity of other systems when operating at full function. The system in question does not interfere with any of the active systems in the vicinity, nor does it suffer any interference.

Electrical interference occurs in vehicle on-board electrical systems because of the various consumers. Mercedes-Benz tests all factory-installed electric and electronic components for their electromagnetic compatibility in the vehicle. If subsequent modifications are made, this may cause a reduction in comfort in some cases (e.g. radio noise).

When retrofitting electrical or electronic systems, they must be tested for electromagnetic compatibility and this must be documented.

All electrical equipment fitted must be tested in accordance with FCC, CE and UL in the US, and with CSA and ULC in Canada.

The notes under Chapter 8.4.4 Connecting additional electrical consumers (→ page 101) and Chapter 4.4 Limit values for electrics/electronics (→ page 53) must be observed.

Information about EMC can be obtained from the following rules and regulations:

- CISPR 12
- CISPR 25
- DIN EN 55012
- DIN EN 55025
- ISO 7637
- ISO 10605
- ISO 11451
- ISO 11452
- MBN 10284
- UN-R-10

8.3 Battery

8.3.1 Main battery

The main battery is located in the right seat base.

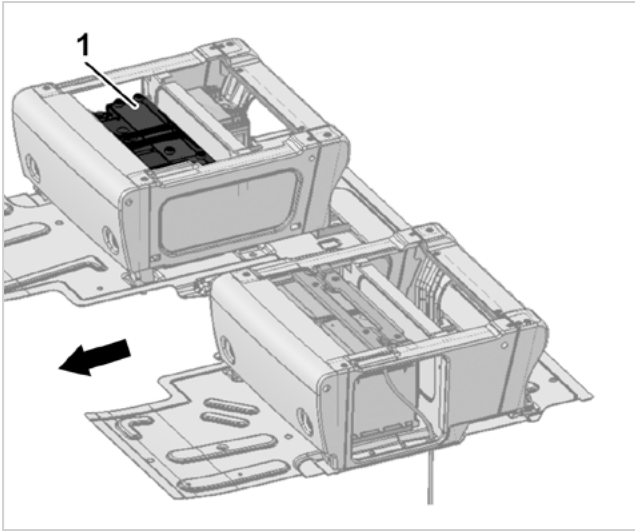

N54.10-2409-00

Installation position of the main battery

1 Main battery
Arrow Direction of travel

Battery (standard)

Code	Battery type	Capacity [Ah]
ED4	AGM battery	92

! NOTE

Electrical cables must not connect directly to the ground terminal of the battery.

! NOTE

The vehicle systems (standard and factory-fitted optional equipment) are powered by the main battery.

If one or more vehicle systems are operated when at a standstill (e.g. operating radio with ignition off), then ensure that the main battery maintains a positive charge balance by starting the engine.

8.3.2 Auxiliary battery

! NOTE

Batteries with capacities of more than 100 Ah may not be directly connected to the on-board electrical system, as this can cause damage to the basic vehicle.

A positive total charge balance is to be assured through selection of a suitable alternator.

Only the same type of battery must be used for main and auxiliary batteries.

When operating loads on the auxiliary battery, ensure that the permissible total current of 80 A across the battery cutoff relay is not exceeded. The battery charging current with the engine running must also be taken into account.

It is recommended to always use the ex-factory special equipment options offered by Mercedes-Benz AG if these equipment are required for an auxiliary battery.

The auxiliary battery is available ex-factory under code E28.

i Additional information on special equipment can be obtained from any Mercedes-Benz Service Center, from the relevant department (→ page 10) or under Chapter 3.10 Special equipment (→ page 44).

If the vehicle is to be started using an external power supply, then either the jump-start connection point or the main battery must be used.

Retrofitting an auxiliary battery

If the auxiliary battery is located in the passenger compartment, sufficiently dimensioned ventilation must be realized through a central vent hose leading into the atmosphere.

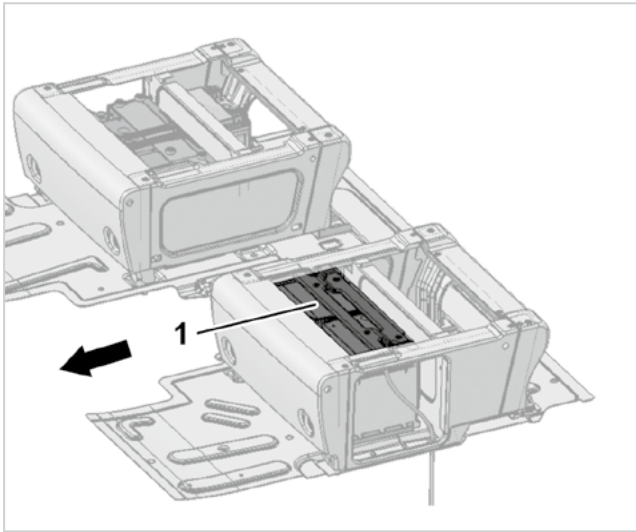

N54.10-2410-00

Installation position of auxiliary battery

- 1 Auxiliary battery
- Arrow Direction of travel

Other auxiliary batteries

! NOTE

If the vehicle is already equipped with an auxiliary battery, further auxiliary batteries may only be connected in parallel with a charging current limiter. This can be realized through supplementary electronics. A maximum charging current for both auxiliary batteries of 80 A must be ensured by the upfitter. If this is not the case, the basic vehicle may be damaged.

Ensure a positive total charge balance through selection of a suitable alternator.

Retrofitting multiple auxiliary batteries requires an evaluation with the responsible department. As part of the ExpertUpfitter program, please refer to www.UpfitterPortal.com.

8.3.3 Support battery (code E34)

The support battery is located in the right seat base.

The support battery helps in stabilizing the on-board electrical system on vehicles with automatic start/stop system.

This feature is discontinued from MY21 Metris.

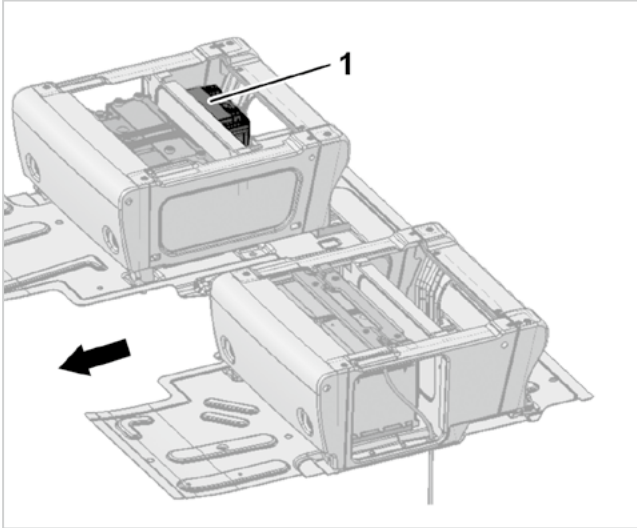

N54.10-2411-00

Installation position of support battery

1 Support battery
Arrow Direction of travel

8.3.4 Backup battery

On vehicles with an automatic transmission and without a support battery, a backup battery is installed in place of the support battery. In the event of a current interruption, this enables the transmission position N or P to be engaged regardless.

8.3.5 Battery maintenance and storage

Batteries must be regularly checked for voltage drop (self-discharge) - even when removed.

i Additional information can be found under Chapter 3.9.2 Battery maintenance and storage (→ page 42).

8.4 Interfaces/electric lines

⚠ WARNING

As all consumers are networked and internally monitored by the system, no modifications should be made to the CAN bus (e.g. breaking, extending or tapping). Any change to the cable harness in terms of length, cross-section or resistance can result in safety-relevant components failing or comfort impairments.

8.4.1 Electric lines

Only cables sheathed with lead-free PVC and with an insulation operating temperature limit of more than 105°C / 221°F may be used. The lines and connections used must be designed professionally and water-tight, and must be protected against impact, heat and abrupt detachment. The line must be dimensioned in accordance with the current level drawn and protected with fuses, see Chapter 4.4.1 Fuses (→ page 53).

Routing of lines

If the routing has to be altered, avoid routing across sharp edges and through narrow cavities or near moving components.

The cable duct must not be damaged or re-routed when carrying out modifications in the area of the transmission tunnel.

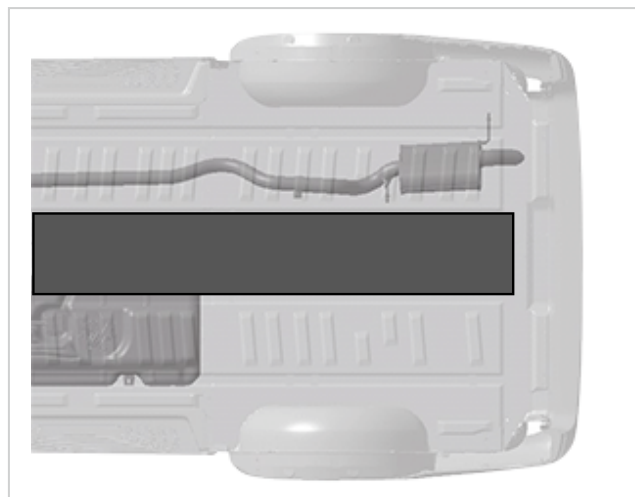

N68.00-3027-00

Cable duct based example of vehicle floor with body length A2

8.4.2 Cable extension

An identical or larger cable cross-section is to be used for cable extensions. We recommend the use of cables that conform with DIN 72551 or ISO 6722-3. The protective effect of retaining elements must not be impaired.

All connections must be designed professionally and water-tight in accordance with IP 69k (resistant to high-pressure cleaning).

8.4.3 CAN bus and networking

The electronic systems available in the engine/passenger compartments are connected to one another via networks (bus systems). Gateways are used to transfer data between the individual bus systems.

These bus systems include:

- LIN bus (Local Interconnect Network)
- Ethernet
- CAN bus (Controller Area Network), including:
 - Body CAN
 - Head unit CAN
 - Chassis CAN
 - Diagnostics CAN
 - Upfitter CAN (special equipment, via PSM/ MPM)
 - Peripheral device CAN (special equipment, via PSM/ MPM)

⚠ WARNING

Any modifications to bus systems can lead to the failure of safety-relevant components.

This can result in accidents or in damage to the vehicle!

Interference with the bus systems (e.g. by disconnecting, extending or "tapping") is not permissible.

Internal and external vehicle diagnosis can be carried out by means of the OBD diagnostic socket (SAE 1962). Every control unit is capable of self-diagnosis and is equipped with an internal fault memory.

Communication with the relevant control unit can be established using the XENTRY Kit test device and the software developed for this unit.

The parameterizable special module (PSM/MPM) (code ED5) can be used to access individual types of data available on the CAN bus (page 110).

i You can obtain further information on this topic from your Mercedes-Benz Service Center.

8.4.4 Connecting additional electrical consumers

⚠ WARNING

Tampering with and unauthorized installations in the vehicle electrics/on-board electronics can impair the functioning of these systems. This may lead to the failure of components or safety-relevant component parts.

This can result in accidents or in damage to the vehicle!

Tampering with and unauthorized installations in the vehicle electrics/on-board electronics are not permissible.

! NOTE

Furthermore, tampering with the vehicle electrics/on-board electronics can invalidate the implied warranty or the general operating permit.

Please observe the following if electrical accessories are retrofitted:

- The alternator and batteries must be of sufficient capacity (positive charge balance). In this case it is necessary to install batteries of a higher capacity (Chapter 8.3 Battery (→ page 97)) and alternators of a higher capacity (Chapter 8.4.6 Retrofitting an alternator (→ page 103)), which are available as special equipment.
- No additional consumers may be connected to assigned fuses.
- No additional lines may be connected to existing lines (e.g. with cut-and-clamp connections).
- Additional electrical consumers must be sufficiently fused using additional electrical fuses.
- The line cross-section must be dimensioned according to the current level drawn, see Chapter 4.4.1 Fuses (→ page 53).
- Electric lines must be routed correctly, see Chapter 8.4.1 Electric lines (→ page 100).
- There must be no impairment of the accessibility or easy maintenance of installed equipment.

- The necessary air supply and cooling of the engine may not be impaired, see Chapter 6.3.3 Engine cooling (→ page 75).
- The guidelines of the equipment manufacturer for compatibility with the basic vehicle must be observed.
- The operator's manual and the maintenance manual for the additional assemblies must be supplied when handing over the vehicle.
- All installed electrical consumers must be electromagnetically compatible, see Chapter 8.2 Electromagnetic compatibility (EMC) (→ page 96).
- A certificate from the manufacturer is sufficient for retrofitted electrical equipment if the equipment has no effect on immunity to interference.
- The connection of additional electrical auxiliary consumers must be carried out using the terminal strip for auxiliary consumers (code EK1) available ex-factory, see Chapter 8.4.5 Power tapping via terminal strip (→ page 102).

8.4.5 Power tapping via terminal strip

The terminal strip for auxiliary consumers (special equipment, code EK1) is located at the A-pillar under the cockpit on the right-hand side in the direction of travel, and has three connections:

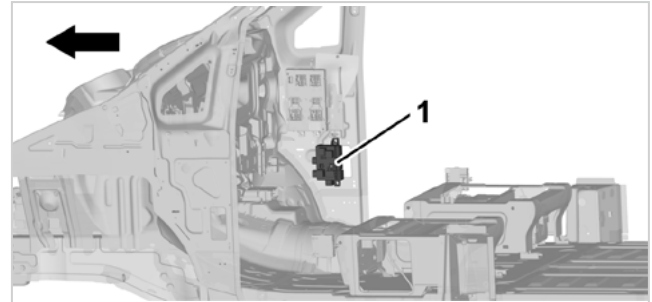

N54.10-2412-00

1 Terminal strip
Arrow Direction of travel

Position	Tml. designation	Fuse	Fuse rating [A]
S9-7	15	F320	15
S4	30	F321	25
S9-9	61	F319	15

The terminal strip EK1 is supplied directly from the main battery and is the supply point in the main on-board electrical system at which the upfitter may connect his consumers. Other consumers can be connected via the PSM (MPM) and the auxiliary battery.

! NOTE

If terminal 30T is used, a positive overall charge balance must be ensured in all vehicle conditions. Do not connect any consumers on terminal 30T of the EK1 which require a current > 1mA when vehicle is idle.

8.4.6 Retrofitting an alternator

When retrofitting additional electrical consumers, the increased current requirement can be met by using a more powerful alternator.

The following alternators are available as special equipment (option codes) from the factory:

Code	I [A]/U [V]	Passenger van	Cargo van
Standard	175/ 14.3	-	Standard
ML4	190/ 14.3	Standard	Optional

The following points must be observed if you intend to have other alternators retrofitted:

- On no account should the installation of an alternator impair vehicle parts or their function.
- The battery (→ page 97) must have sufficient capacity and the alternator must generate sufficient power.
- The alternator circuit must be provided with additional fuse protection, see Chapter 4.4.1 Fuses (→ page 53).
- The line cross-section must be dimensioned according to the current level drawn, see Chapter 4.4.1 Fuses (→ page 53). The higher power draw may necessitate the replacement of the starter/alternator wiring harness. For this, we recommend the use of Mercedes-Benz genuine parts.
- Electric lines must be routed correctly (→ page 100).
- There must be no impairment of the accessibility or easy maintenance of installed equipment.
- There must be no impairment of the required engine air supply and cooling (→ page 75).
- The guidelines of the equipment manufacturer for compatibility with the basic vehicle must be observed.
- The operator's manual and the maintenance manual for the additional assemblies must be supplied when handing over the vehicle.

8.4.7 Speed signal

The "Highline" and "Lowline" instrument clusters output an electronic speed signal at pin 9 of the instrument cluster connector.

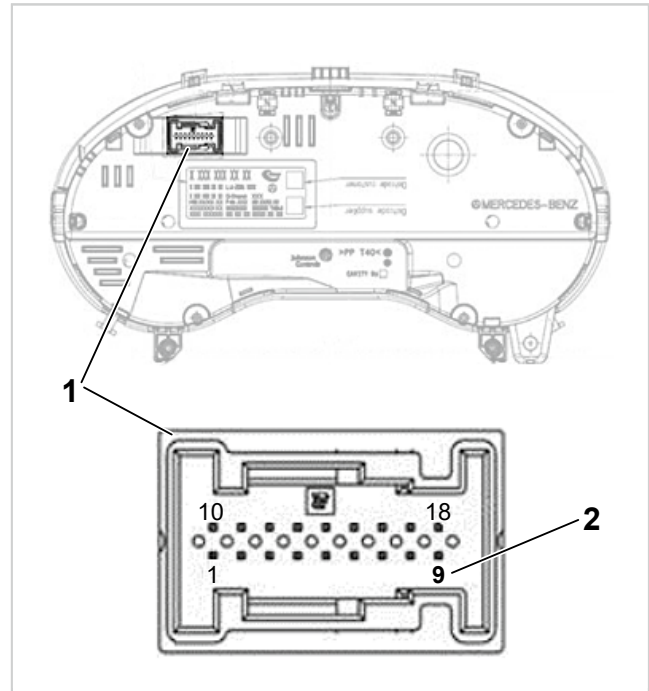

Equipment plug on rear of instrument cluster

- 1 Equipment plug
- 2 Pin 9

It should be noted that this speed signal is dependent on coded parameters (including tire size and tire characteristic), and therefore the travel distance signal from the PSM is recommended for calibrated taximeters or similar equipment, see Chapter 8.4.8 Travel distance signal Chapter 8.4.8 Travel distance signal (→ page 104).

The speed signal (positive to ground) acts as a distance and speed signal for external electronics, e.g. taximeters or speed-dependent volume controllers. The signal is protected against short-circuit to ground and battery voltage and is not monitored.

The signal is output at 4 pulses per meter. The pulse width is 4 ms.

At 112.5 km/h or 69.9 mph, the pulse duration is the same as the pulse pause. This 1:1 ratio is maintained for higher speeds. This means that, at higher speeds, the pulse length and the pause length become shorter at the same time.

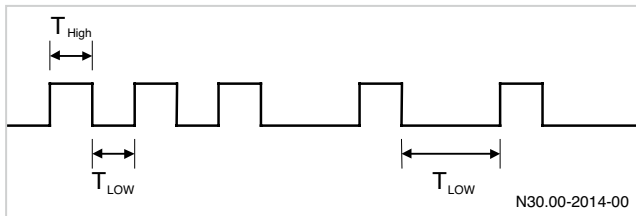

Ratio of pulse duration/pulse pause

Speed signal ($I_{max} = 20 \text{ mA}$):

$T_{High} U_a \geq 8 \text{ V}$

$T_{Low} U_a \leq 1 \text{ V}$

Value range: 0 - 250.996 km/h

Resolution: 1/256 km/h

8.4.8 Travel distance signal

A travel distance signal is permanently present at PSM output 15 (plug 2, pin 3). When the ignition is off, no wheel speed pulses are sent. The pulses are accurate at speeds of 3 km/h (1.86 mph) and above. When the PSM control unit is in OFF mode, the wheel speed (RDZ) signal output driver is deactivated. 48 pulses/revolution are output (96 signal flanks/revolution) in the vehicle speed range from 0 km/h to 362 km/h or 0 mph to 225 mph. This results in an output frequency from min. 0 Hz to max. 2414 Hz.

8.5 Illumination

8.5.1 Adjusting the headlamps

The local and national registration regulations must be obeyed.

The headlamp basic setting must be observed (see identification plate).

Only check the headlamp setting with the vehicle unladen (ready to drive – full tank and with 1 driver or 75kg / 165.35 lbs load).

- ▶ Park the vehicle on a level, horizontal surface.
- ▶ Align the headlamp adjuster and the vehicle at right angles to each other.
- ▶ Correct the tire pressure (see tire pressure table).
- ▶ Move the headlamp range control to the basic setting **0**.
- ▶ Switch on the headlamps.
- ▶ Every headlamp must be checked separately and the second headlamp and other lamps must be blacked out while doing so.

The light-dark boundary of the low beams at a distance of 10 m can be calculated from the height of the headlamp (center of headlamp to ground) minus the specified headlamp basic setting.

Basic setting of LED headlamps

For vehicles with LED headlamps, the basic setting must be applied in a Mercedes-Benz Service Center using XENTRY Kit.

Headlamp basic setting:

1% = 10 cm / 3.94 in, 1.5% = 15 cm, 2% = 20 cm / 7.87 in etc.

8.5.2 Covering of illumination equipment

The local and national registration regulations must be obeyed.

If moving vehicle parts cover lighting equipment by more than 50% during operation, the vehicle must be safeguarded accordingly.

An appropriate note must be attached at a point where it can easily be seen by the driver of the vehicle.

Detailed information about the installation of illumination and signaling equipment and the requirements on the coverage of illumination and signaling equipment can be found in the relevant safety standards such as FMVSS 108 and CMVSS 108.

8.5.3 Vehicle position lamps/clearance lamps

Clearance lamps increase passive safety and are required by law on vehicles with width of greater than 2.032 m/ 80 in (FMVSS/CMVSS 108). Clearance lamps may be installed for vehicles with width larger than 1.80 m/ 70.87 in.

8.5.4 Exterior lamps

Lamp monitoring

The signal acquisition and actuation module (SAM) monitors all outputs for open load (wire break) and short circuit. If a lamp is not connected or is overloaded, a fault entry is stored in the memory of the SAM control unit. The vehicle owner or the driver must be informed. It is recommended that an entry be made in the service booklet. The fault entry must be addressed during a service if read out using XENTRY Kit.

Additional lamps

Additional lamps must be connected via the PSM (MPM) or a separate cube relay. A standard cube relay ($R_i > 80 \text{ ohm}$) can optionally be connected in parallel with the exterior lamps (with the exception of the center high-mounted brake lamp, turn signals, license plate lighting, side markers and clearance lamps). This will not have any negative effect on lamp monitoring.

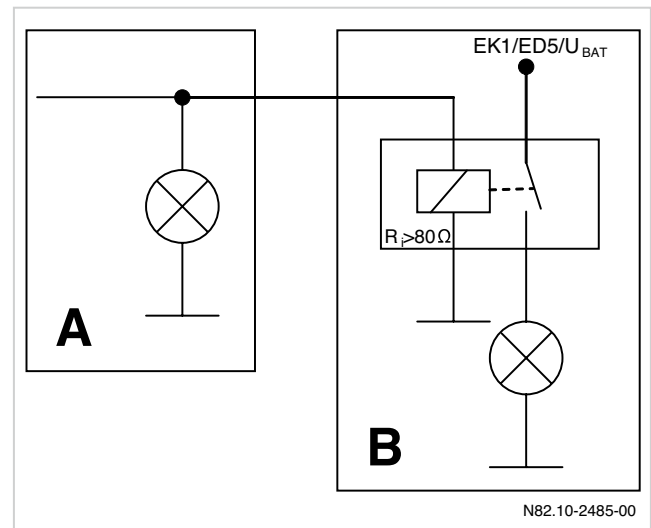

Connection of an additional lamp

- A Scope of the basic vehicle
- B Scope of the upfitter

8.5.5 Interior lamps

The information about the lamps and switches installed and the switching commands for the interior lights are transmitted by the BC via LIN to the overhead control panel.

The overhead control panel also transmits the information about whether and which push button switches are actuated over LIN to the BC.

The following SA codes for interior lighting are available ex factory.

SA code	Name/description
LB9	Exit lamps - The exit lamps ensure greater safety, comfort and convenience for the driver and front passenger when getting in and out of the vehicle in the dark. They are built into the driver and front passenger doors below the door trim and switch on when the door is opened.
LC2	Light strip in load compartment - The LED light strip in the load compartment is located in a high position at the rear in such a manner that the load compartment is illuminated with a minimum of shadow. The LED technology enables low power consumption and impresses with a long service life.
LC3	Illumination in rear grab handles - The pleasantly discreet illumination of the grab handles in the rear passenger compartment makes it easier for the passengers to find their way about in the dark. The interior lighting is switched on and off by means of a pushbutton switch integrated into the grab handle. It is switched on automatically when the vehicle is unlocked or the door is opened.
LC4	Comfort overhead control panel - The luxury comfort overhead control panel features numerous lighting functions, some in innovative LED technology with fiber-optic cables. The interior lamps and the cockpit upright pleasantly illuminate the interior and make orientation in the dark easier. The reading lamps for the driver and front passenger provide spot lighting for reading. The focused light beam is aimed downwards to avoid dazzling the driver or front passenger. The lighting functions are operated with buttons and switches integrated in the overhead control panel.
LC6	Illumination in rear grab handles with reading spotlight - The illumination of the grab handles with reading spotlight in the rear passenger compartment provides a pleasant and functional light. The interior light provides a discreet lighting mood. The focused light of the additional spotlight enables passengers in the rear seat rows to read. The light sources for the interior light and the reading spotlight are 2 separately switchable LED lamps.
LC7	Illumination for front footwell - The LED footwell lighting illuminates the driver and front passenger footwells, helping to provide a pleasant lighting mood in the vehicle interior.
LC8	Liftgate surround lighting - The surround lighting in the liftgate makes it easier to load and unload the vehicle in darkness. It consists of a white lamp, which illuminates the surroundings below the liftgate, and a red warning lamp that shines backwards. This provides a visual warning of the open liftgate, improving perceptual safety.
LD9	Interior lamp(s) in the rear - The two additional interior lamps improve visibility when getting in and out of the vehicle and when loading and unloading.

! NOTE

All interior lamps can be replaced by other after-market lamps. In order to ensure that the standard bulb failure monitor functions correctly, only light sources of the same type and same output rating as standard bulbs may be installed.

Lamp monitoring

The overhead control panel or the Body Controller monitors all outputs for open load (wire break) and short circuit.

If a lamp is not connected or is overloaded, a fault entry may be stored in the fault memory of the Body Controller. The owner or driver of the vehicle must be informed about this. The fault entry must be addressed during a service if the fault memory is read.

The interior lights can also be actuated via the PSM (MPM). See Chapter 8.8 Parameterizable special module PSM (MPM) (→ page 119).

8.6 Mobile communications systems

If mobile communications systems (e.g. telephone, CB radio) are retrofitted, the following requirements must be fulfilled in order to avoid malfunctions developing on the vehicle at a later stage.

All electrical equipment installed on the vehicle must be EMC-compliant and tested in accordance with FCC, CE, and UL in the U.S. and with CSA and ULC in Canada.

8.6.1 Equipment

The maximum transmission output (PEAK) at the base point of the antenna must not exceed the following values. Moreover, country-specific laws regarding the maximum permissible transmission output must be observed.

Frequency range	Maximum transmission output [W]
Short wave (SW) 3 - 54 MHz	100
4 m band 74 - 78 MHz	30
2 m band 144 - 174 MHz	50
Trunked radio system/ Tetra 380 - 460 MHz	35
70 cm band 400 - 460 MHz	35
GSM/DCS/PCS 850/900/1800/1900	10
UMTS/LTE	10

- The mobile communications systems and brackets must not be positioned in the deployment areas of the airbags (→ page 77).
- Equipment must be permanently installed. Portable or mobile devices may only be operated inside the cab if they are connected to an exterior antenna which has been installed in such a manner that it is reflection-free.
- The transmitter unit must be installed as far away from the vehicle's electronic system as possible.
- The unit must be protected against moisture and heavy physical shocks; the permissible operating temperature must be observed.

8.6.2 Antenna connection and cable routing (radio communication)

- Comply with manufacturer's notes and installation instructions.
- An antenna can be installed anywhere on the roof. The maximum transmission output must not be exceeded.
- The connection should be made directly to terminal 30 via an additional fuse. Disconnect the unit from the electrical system before starting assistance.
- The lines must be kept as short as possible. The lines must be twisted and screened (coaxial cable). Chafe marks must be avoided.
- Ensure that the system has a good ground connection to the body (antenna and equipment).
- The antenna and connecting cables between the transmitter, receiver and operating panel must be routed separately from the vehicle wiring harness in the vicinity of the body ground.
- Route the antenna line in such a way that it is not kinked or pinched.
- Comply with local and national regulations on the transport of hazardous goods.

The notes in Chapter 5.3 Anti-corrosion protection measures (→ page 57) and Chapter 5.4 Painting work/preservation work (→ page 59) must be observed.

8.7 Driving assistance systems

⚠ WARNING

Driving safety and assistance systems are merely aids.

If you fail to adapt your driving style or if you are inattentive, the driving safety systems and driving assistance systems can neither reduce the risk of an accident nor override the laws of physics. The driver is responsible for driving safely according to the traffic conditions (maintaining a safe distance, controlling the speed of the vehicle and braking in good time). Their driving style must always be adapted to suit the current road, traffic and weather conditions.

The driving safety systems described only work as effectively as possible when there is adequate contact between the tires and the roadway. Please pay special attention to the notes on tires, recommended minimum tire tread depths etc. under Chapter 3.6 Tires (→ page 36), Chapter 4.4.2 Vehicle position lamps and side marker lamps (→ page 53) and Chapter 6.2.4 Fenders and wheel wells (→ page 70).

In wintry driving conditions, always use winter tires (M+S tires) and, if necessary, snow chains. Only in this way will the driving assistance systems described in this section work as effectively as possible.

i Further information on equipping the vehicle with driving assistance systems and their possible combinations can be obtained from the department at “Advice for upfitters”(→ page 10).

⚠ WARNING

Tampering with or unauthorized installations in vehicle systems, safety-relevant components and driving assistance systems can impair the functioning of these systems. This can lead to failure or malfunctioning of components or of parts relevant to safety, and may result in accidents or damage to the vehicle.

- i** Furthermore, tampering with the vehicle, safety or driving assistance systems and safety-relevant components can invalidate the warranty or the general operating permit.
- i** Not every one of the systems described in this chapter is available in every vehicle. Information regarding the equipment on vehicles with driving assistance systems and regarding the combinations thereof can be obtained from the Basic Vehicle Technical Consulting team (→ page 10).

Overview of assistance systems in the Metris

8.7 Driving assistance systems	Code
8.7.1 Electronic Stability Program (ESP®)	-
8.7.2 Crosswind Assist	-
8.7.3 Active Brake Assist	BA3
8.7.3 Active Distance Assist DISTRONIC	ET4
8.7.4 Blind Spot Assist	JA7
8.7.5 Lane Keeping Assist	JW5
8.7.6 Rain sensor	JF1
8.7.6 Automatic driving lights	LA2
8.7.7 Tire pressure loss detection system	RY2
8.7.8 Parking assistance systems - Active Parking Assist	EZ7
8.7.8 Parking assistance systems - Reversing camera	FR8

8.7.1 Electronic Stability Program (ESP®)

ESP® is a dynamic vehicle control system which regulates both the longitudinal and lateral dynamics of the vehicle.

Greater driving stability is provided by ESP® with an extended sensor system that constantly compares the current actual vehicle direction with the driver's desired direction of movement.

ESP® can improve vehicle stability in all driving situations – when accelerating, braking and coasting, when driving in a straight line and when cornering.

Together with the signals of other sensors, a processor monitors that the direction specified by the driver is maintained.

If the vehicle deviates from the correct path (over-steering or under-steering), the system can produce a stabilizing counteraction by applying the brakes on individual wheels

Please note ESP® is required on passenger cars, multipurpose passenger vehicles, trucks and buses with a gross vehicle weight rating of 4536 kg/10000 lbs or less, according to FMVSS/ CMVSS 126.

▲ WARNING

On no account may any of the following modifications be made to vehicles equipped with ESP®:

- Modifications to the permissible gross mass
- Wheelbase modifications outside the approved ranges or as-built configurations
- Modifications to the sensors (steering angle sensor, yaw rate sensor, wheel speed sensor, vacuum sensor)
- Changes to the vibration characteristics at the installation location of the yaw rate sensor by modifications to the body
- Changes to the position of ESP® components
- Modifications to the suspension
- Modifications to wheels and tires
- Modifications to the engine
- Modifications to the steering
- Modifications to the brake system
- Changes to the installation position of the hydraulic unit, the bracket and its attachment on the basic vehicle, as the ESP® turn rate sensor is integrated into the ESP® control unit.
- Fastening of any vibration-generating devices in the vicinity of the ESP® control unit.
- Changes to the center of gravity beyond the maximum permissible values for the CoG position are not permitted.

Modifications to vehicles with ESP® may cause this system to stop functioning correctly and may lead to system shutdowns and incorrect control interventions. The driver could lose control of the vehicle and cause an accident.

If the vehicle is additionally equipped with the Crosswind Assist function, also refer to Chapter 8.7.2 Crosswind Assist (→ page 112).

The installation location, installation position and mounting of the ESP® turn rate sensor must not be changed from the production vehicle.

The sensor cluster is integrated in the ESP® and is located on the front left in the engine compartment in left-hand drive vehicles and on the front right in the engine compartment in right-hand drive vehicles.

The ESP® turn rate sensor is identifiable by its black square housing with white adhesive label.

For safety reasons, ESP® turn rate sensors may no longer be installed if they have been dropped on the floor. In this case, a Mercedes-Benz genuine part from must be installed.

8.7.2 Crosswind Assist

Crosswind Assist detects the influence of crosswind (track offset) through the installed ESP® components and can counteract it by applying the brakes on individual wheels with the help of the ESP®.

i Information on the availability of Crosswind Assist can be obtained from the Basic Vehicle Technical Consulting team (→ page 10).

Any body mounting work on the vehicle which brings about changes to the projected lateral face is only allowed to a limited extent and a UIS is requested to be opened for Expert Upfitters planning changes (→ page 10).

The retrofitting of high roof attachments, for example, is one measure which alters the projected lateral face. A change in the lateral face leads to a change in parameters, which could influence the functioning of the system.

Crosswind Assist cannot be deactivated.

i Additional information is available from the Upfitter Management Vans (→ page 10).

i The Electronic Stability Program (ESP® 9.3) is a prerequisite for the Crosswind Assist function. The addition of code JA8 ex factory is also valid for uprated and downrated variants.

i The local and federal registration regulations must be observed and complied with when working on the body of the vehicle.

8.7.3 COLLISION PREVENTION ASSIST and DISTRONIC PLUS assistance systems

Active Distance Assist DISTRONIC PLUS (code ET4) and Active Brake Assist (code BA3)

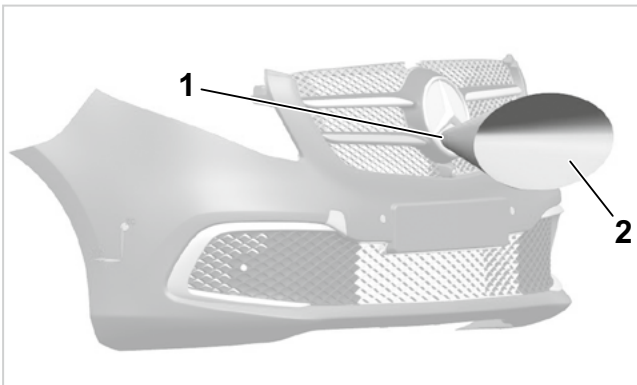

Sensor position for DISTRONIC PLUS and Active Brake Assist

- 1 Sensor
2 Signal funnel

The two systems detect objects via a radar sensor and output warnings visually and acoustically via the instrument cluster, as well as the requests for acceleration and braking interventions.

The sensor (transmitter and receiver) is integrated behind the Mercedes star in the radiator grille. This is made of transparent material.

To ensure that the functioning of the system is not affected, on no account should the following changes be made:

- Changing the position of the sensor
- Replacement of sensor with integrated Mercedes star
- Attachment of detachable parts that can shadow the area of or around the sensor. If necessary, the system must be deactivated.

The DISTRONIC PLUS is operated with the control lever on the left of the steering wheel. Active Brake Assist can be activated and deactivated via a menu in the instrument cluster.

⚠ WARNING

The area of or around the sensor must not be painted or covered with a film.

Depending on the version and thickness, paints or film coatings can cause dampening of radar waves. This could lead to malfunction or system failure. The driver could lose control of the vehicle and cause an accident.

⚠ WARNING

If the detection function for the seat buckles, the door locks (front, side, rear) and the hood catches is modified or disabled, the functioning of the DISTRONIC PLUS can be impaired or can fail entirely.

! NOTE

If the front end of the vehicle is damaged, please have the settings and function of the radar sensor checked and recalibrated at a qualified specialist workshop, e.g. at a Mercedes-Benz Service Center. If necessary, new parameters for the sensor installation height must be observed. This also applies to mild collisions at low speeds, where no damage to the front end of the vehicle is visible.

! NOTE

In the event of suspension level changes, e.g. due to major changes in the weight of the vehicle or in the position of the vehicle's overall center of gravity in the x-direction (vehicle longitudinal direction) towards the front or rear (as a result of vehicle upfit), the vertical and angular adjustment of the DISTRONIC PLUS radar sensor must be checked by a qualified specialist at Mercedes-Benz Service Center and recalibrated if necessary.

8.7.4 Blind Spot Assist

The sensors of the Blind Spot Assist system are integrated into the side of the rear bumper. The signaling to the driver takes place visually via illuminated symbols in the outside mirrors and acoustically via a warning tone.

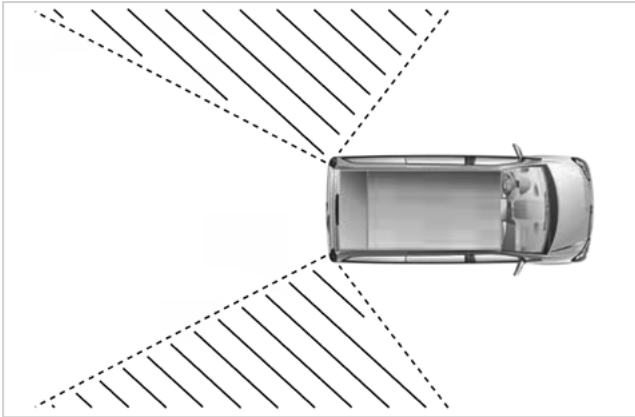

N54.70-2037-00

Sensor positions and detection ranges of Blind Spot Assist

To ensure that the functioning of the system is not affected, on no account should the following changes be made:

- Changing the position of the sensors
- Removing or modifying detachable parts in the area of the sensors
- Attachment of detachable parts that can shadow the area of or around the sensor
- Modifications to outside mirrors

Blind Spot Assist can be deactivated via a menu in the instrument cluster.

The Rear Cross Traffic Alert (RCTA) function, available from MY22 Metris, can detect cross traffic up to a speed of 10 km/h while reversing from e.g. an exit or parking space. A possible source of danger, such as cars or buses, is visually warned via the red triangles in the side mirrors as well as an acoustic signal. If the Blind Spot Assist is deactivated, then the Rear Cross Traffic Alert is also switched off.

⚠ WARNING

The area of or around the sensor must not be painted or covered with a film.

Depending on the version and thickness, paints or film coatings can cause dampening of radar waves. This could lead to malfunction or system failure. The driver could lose control of the vehicle and cause an accident.

There is a risk of accident!

! NOTE

If the areas of the sensors are damaged, please have the settings and function of the radar sensors checked and recalibrated at a qualified specialist workshop, e.g. at a Mercedes-Benz Service Center. If necessary, new parameters for the sensor installation height must be observed. This also applies to mild collisions at low speeds, where no damage in the areas of the sensors is visible.

Also, if the installation position of the sensors is changed, e.g. due to alterations to the vehicle weight, the suspension, the overhang or similar, the installation position must be checked by a qualified specialist, and it may be necessary to re-parameterize the system to ensure that it will function correctly.

8.7.5 Lane Keeping Assist

! NOTE

On vehicles with bodies which extend beyond the limits illustrated below, the function of the camera may be impaired.

Therefore, it is not recommended to install Lane Keeping Assist on vehicles with bodies that protrude beyond this limit.

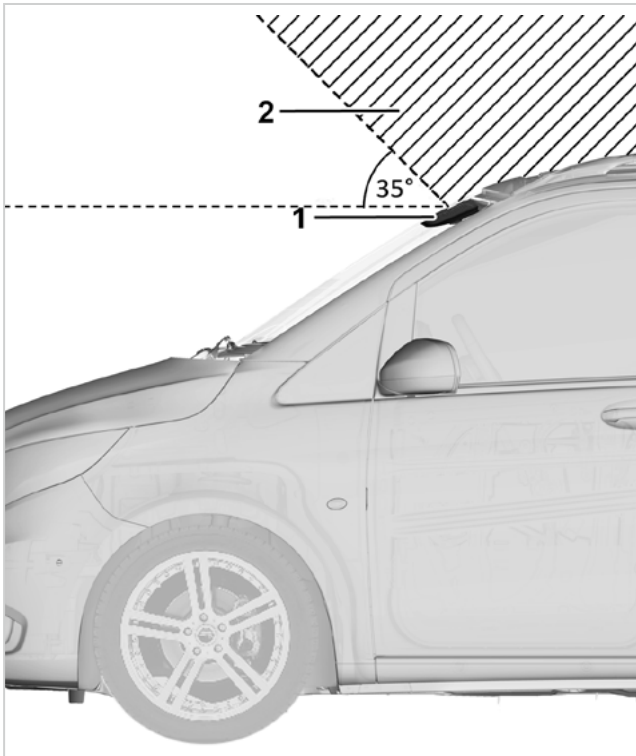

N54.71-2007-00

Limit for bodies on vehicles with sensors for Lane Keeping Assist (schematic diagram)

- 1 Camera
- 2 Body limit

! NOTE

On no account should any modifications be made to the position of the sensors for Lane Keeping Assist or to the surrounding area (e.g. changing the standard windshield). Otherwise the Lane Keeping Assist may no longer function correctly.

The camera must be readjusted after any modifications to the vehicle which alter the vehicle inclination, e.g. replacement of a suspension strut. Have the readjustment carried out at a qualified specialist workshop possessing the required expertise and tools in order to perform the necessary work. Upfitter Management Vans recommends that you use a Mercedes-Benz Service Center for this purpose.

▶ Lane Keeping Assist can be deactivated using a button on the operating panel.

ⓘ Further information on the adjustment of Lane Keeping Assist can be found in the Workshop Information System (WIS) (→ page 12).

8.7.6 Rain sensor / Automatic headlights

The rain sensor (code JF1) and automatic headlights (code LA2) may only be installed with Mercedes-Benz windshields; otherwise, there is a risk of malfunction.

! NOTE

Changes to the position of the sensor for automatic headlights and of the rain sensor and its surrounding area (e.g. by changing the standard windshield) are prohibited as these changes can impair correct functioning of the systems.

! NOTE

On vehicles with bodies which extend beyond the limits illustrated below, the function of the rain sensor/automatic headlights may be impaired. Therefore, it is not recommended to equip vehicles which have bodies that extend beyond these limits with a rain sensor/automatic headlights.

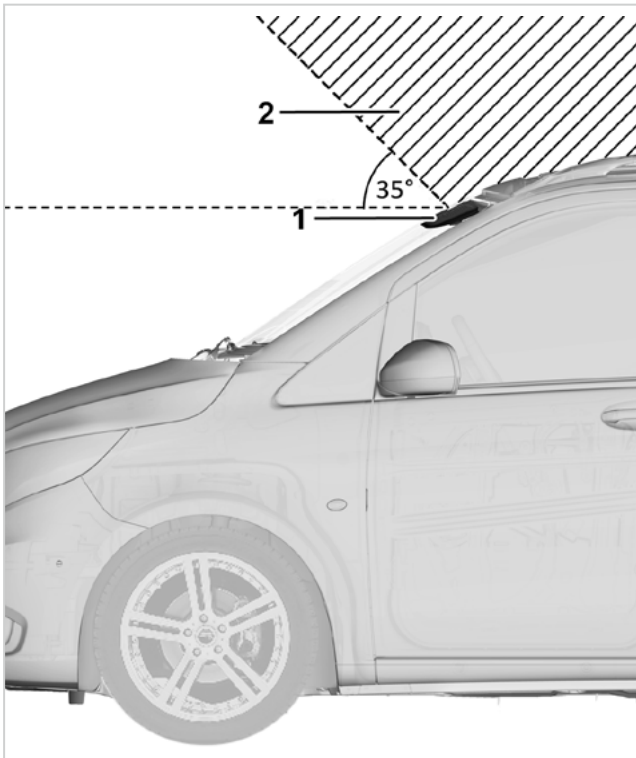

Limit for bodies on vehicles with rain sensor/automatic headlights (schematic diagram)

- 1 Rain sensor/automatic headlights
- 2 Body limit

! NOTE

There must be no infrared-absorbing films on the windshield in the area of the sensor.

8.7.7 Tire pressure loss detection system

! WARNING

Do not make any modifications in the area under the floor of the vehicle, including the vehicle axles and the system components of the tire pressure monitoring system. Otherwise, the function of the tire pressure monitoring system may be compromised by the effects of electromagnetic reflections. This might result in the driver being unaware of any tire pressure loss, and they could cause an accident.

Furthermore, the vehicle may no longer meet certification requirements.

The wireless tire pressure monitoring system on the front and rear axle (code RY2) is offered as a standard option on all Metris vehicles. Modifying the components of this system or influencing them by modifying or adding electromagnetic fields or repositioning the system components is not permitted.

The system's reception module/ control unit is affixed to the outside, on the vehicle floor plate above the rear axle differential. The pressure sensors are integrated in the tire valves.

If body work is planned for the vehicle underbody, an evaluation with the responsible department is necessary. As part of the ExpertUpfitter program please refer to www.UpfitterPortal.com. Upfitter Management Vans does not issue certificates for body equipment in connection with this vehicle system.

After body work in this area, another inspection of the tire pressure loss detection system by an officially recognized testing organization may be required at the upfitter's expense. This serves to prove that the vehicle registration eligibility still exists as the tire pressure monitoring system has not been affected.

All relevant national and local regulations must be complied with.

8.7.8 Parking assistance systems

Parking Assist PARKTRONIC

- If approved detachable parts are retrofitted, it is necessary to have the Parking Assist PARKTRONIC coded with the appropriate parameter set by your Mercedes-Benz partner.
- Aftermarket painting of the bumper is not permitted with the PARKTRONIC ultrasonic sensors fitted. The coat of paint impairs the emission and reception of the ultrasonic signals.

! NOTE

Sensors which are already painted must not be repainted or touched up.

In order to ensure that they function correctly throughout their operating life, sensors must be painted before being installed.

Unpainted sensors and sensors painted in a range of colors are available from Mercedes-Benz.

The maximum thickness the paint coat on the cover may have without impairing sensor operation is 120 µm. This also includes repeated paint applications and the coat from cathodic dip painting (KTL coat). The KTL coat thickness is between 12 µm and 25 µm.

It is therefore necessary to make spot checks of the paint coat thickness to ensure faultless operation of the sensors.

It is essential that not only the cover itself but also the cylindrical edge of the sensor diaphragm be coated with paint evenly all the way round and covering at least 2 mm.

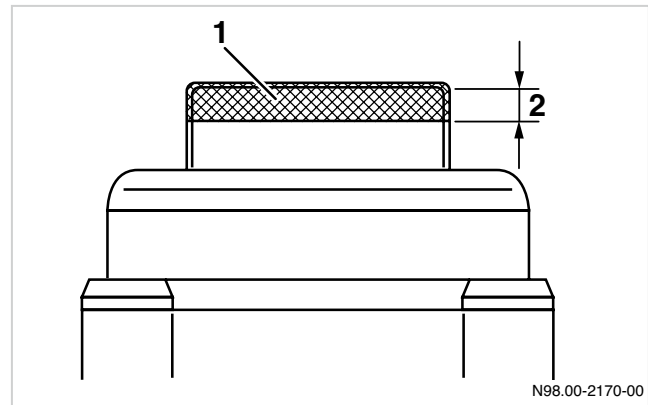

Area of cylindrical edge of the sensor membrane to be painted

- 1 Area to be painted
- 2 Maximum coat thickness 120 µm

! NOTE

The coat of paint may not be ground off mechanically, as this could damage the chromate/cathodic dip coating or the sensor diaphragm.

! NOTE

If the surface has been cathodic dip primed, the paint must not be removed by chemical means as this could damage the cathodic dip coating. A new coating cannot be applied afterwards. Nor is it permitted to touch up damaged areas chemically or mechanically.

! NOTE

Detachables parts fitted in the detection range of the sensors may impair operation of the Parking Assist PARKTRONIC system (e.g. trailer coupling, overhangs of bodies, wheel carriers, steps, brush guards).

Reversing camera

The reversing camera with 180° angle of vision is integrated in the rear area of the vehicle.

- In vehicles with liftgate, the reversing camera is located beside the liftgate handle.
- In vehicles with hinged rear doors, the reversing camera is at the top of the license plate holder.

Vehicles with liftgate

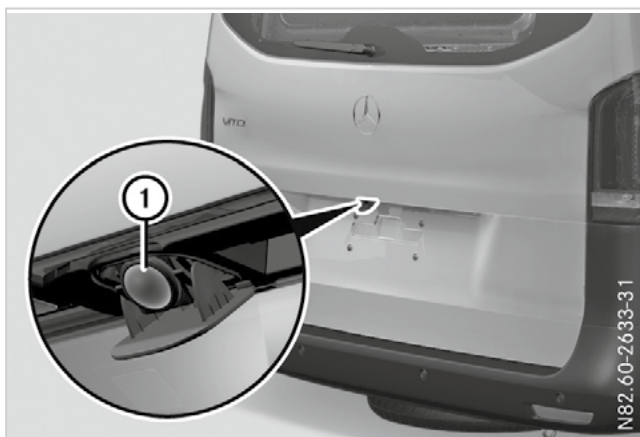

Installation location of reversing camera in Metris with liftgate

- 1 Reversing camera

Vehicles with hinged rear-end doors

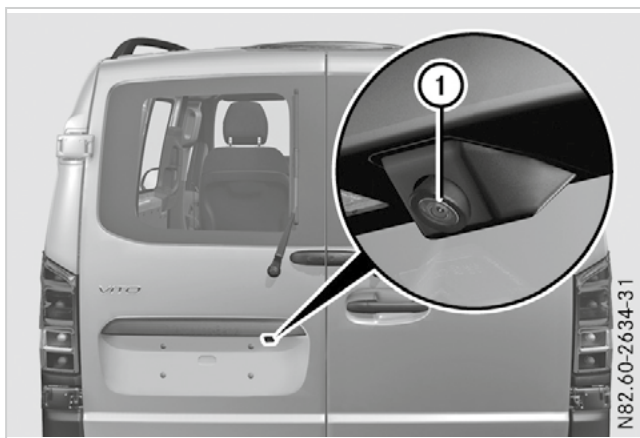

Installation location of reversing camera in Metris with hinged rear door

- 1 Reversing camera

⚠ WARNING

Changes made to the position of the installed camera or caused by bodies that extend into the angle of vision of the camera may mean that the system can no longer function correctly under certain circumstances. This may cause people, animals or objects not to be seen in the area in which you are maneuvering. For this reason, do not make any changes in the area of the camera.

! NOTE

The functional and system limits of the reversing camera must be observed; please see the operator's manual.

8.8 Parameterizable special module PSM (MPM)

Parameterizable Special Module (PSM), or also known as Multi-Purpose Module (MPM), is an electronic control unit that connects to the vehicle's CAN bus system and can read and control various vehicle functions. Because Mercedes-Benz restricts modifications of the CAN bus system and direct access to the vehicle networks, PSM has been developed to provide an indirect access to the vehicle CAN bus. PSM (MPM) provides a clearly defined, diagnostics-compatible and EMC-tested interface between the vehicle and the upfit.

PSM (MPM), available under code ED5, can read the messages on the CAN bus and, for example, make them available as switching signals at the binary outputs or as PWM (pulse width modulation) signals. The electronics installed by the upfitter then have access to the necessary signals.

PSM control unit is located in the driver seat box.

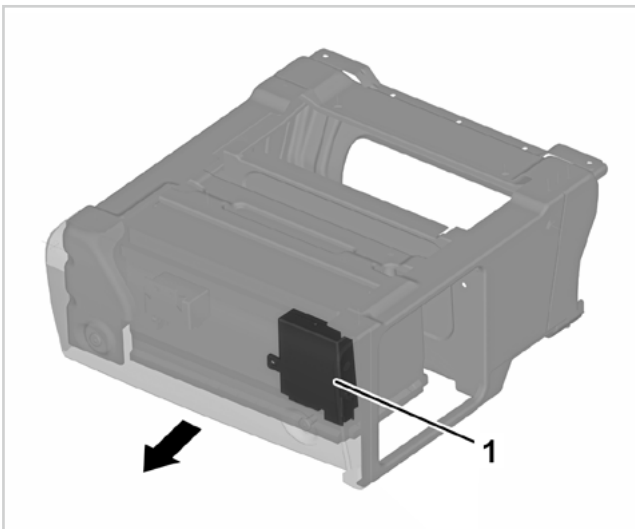

N54.21-2173-00

Installation position of the PSM (MPM) in the left seat base

1 Parameterizable special module PSM (MPM)
Arrow Direction of travel

NOTE

The wiring on the vehicle must not be tampered with, as this would lead to fault messages from the other control units on the CAN bus.

Please utilize fuses for any electronic consumers connected to PSM.

- ① The PSM (MPM) is parameterized using XENTRY Kit (→ page 13).
- ① Information about possible parameterizations can be found in the detailed "PSM (MPM) Information" which is available in the Upfitter Portal under <https://www.upfitterportal.com/en-us/tech-info/psm-info>
- ① Information on standard parameterization possibilities can be obtained from your Mercedes-Benz Service Center.

NOTE

When a PSM program is uploaded onto the PSM module, all previous parametrization is erased. We recommend saving the stored parametrization before uploading a new PSM program or modifying an existing PSM software.

8.8.1 PSM (MPM) functions

PSM can read customized signals from the vehicle and perform specified vehicle functions.

Read-in examples from body CAN:

- Vehicle status
 - Ignition on (Terminal 15)
 - Engine running (Terminal 61)
- Light status
 - Rotary light switch and steering column switch requests (e.g. high beams, turn signals, low beams, front fog lamps etc.)
 - Hazard warning flashe
 - Window status
 - Windshield wipers and rear wiper
 - Windshield and rear window heaters
- Central locking system
 - Doors open/closed, unlocked/locked
- Chassis CAN information
 - Wheel speed
 - Speed
 - Engine speed
 - Cruise control operation
 - Brakes applied
 - Transmission
 - Clutch information
 - Steering angle
 - Tachograph information as per FMS standard
- Equipment features
 - Door installation
 - Sliding sunroof
 - Transmission

Output examples to body CAN

- Light control
 - Parking lights
 - Standing lights
 - Turn signals
 - High beams
 - Alarm functions
 - Alarm/flashing of high beams
 - Front fog lamp
 - Hazard warning flasher
 - Horn
- Central locking function
 - Lock/unlock front, load compartment and overall vehicle
- Windshield and rear window
 - Windshield wipers and rear wiper
 - Windshield and rear window heaters
- Various functions
 - Actuate buzzer and interior lights

! NOTE

Lock/ unlock function by PSM is internal lock/ unlock feature cannot override the external lock/ unlock function by the key FOB.

8.8.2 PSM (MPM) interfaces

- I/O module
 - 10 parameterizable inputs
 - 19 parameterizable outputs
- Logic functions (mini-PLC)

The mini-PLC (mini programmable logic controller) is a module with freely programmable and freely interconnectable function blocks for creating any signal links that may be required:

 - 96 AND/NAND/OR/EXOR/NOR/EXNOR gates
 - 24 RS and D flip-flops
 - 12 retriggerable/non-retriggerable timer stages
 - 12 hysteresis elements with adjustable thresholds
 - 24 threshold switches with 3 stages
 - 12 counters
- Arithmetic unit
 - 20 calculating blocks
 - 8 filters
 - 8 integrators/differentiators
 - 8 comparators
 - 4 characteristics
 - 16 non-volatile memories
 - 20 freely definable constants

PSM consists of two plugs with input and output pins that upfitters can connect to. Below image provides detailed information on each pins on PSM (MPM).

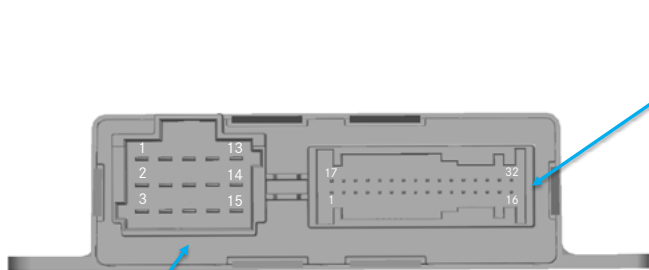

Plug 1

Pin	Circuit	Rating (A)	Type
1	Vehicle Power	-	-
2	Output 2	10	High Side
3	Output 5	5	High Side
4	Vehicle Power	-	-
5	Output 1	5	High Side
6	Output 18	5	High Side
7	Output 4	10	High Side
8	-	-	-
9	GND*	7.5	-
10	Vehicle Power	-	-
11	Output 3	5	High Side
12	Output 19	5	High Side
13	Vehicle Power	-	-
14	Output 20	5	High Side
15	Vehicle GND	-	-

* Can be utilized as a GND source

Plug 2

Pin	Circuit	Rating (A)	Type
1	Output 11	0.5	Low Side
2	Output 14	0.5	Low Side
3	Output 15 (PWM fix)	0.5	Low Side
4	Output 8	0.5	High Side
5	Output 9	0.5	High Side
6	Output 10	0.5	High Side
7	Input 5	-	Low Side
8	Input 6	-	Low Side/ Analog
9	Input 1	-	Low Side/ Analog
10	Input 10	-	Low Side/ Analog
11	Input 7	-	Low Side/ Analog
12	-	-	-
13	GND*	1	-
14	CAN GND	-	-
15	GND*	1	-
16	ABH CAN-H	-	-
17	Output 13	1	Low Side
18	Output 17	1	Low Side
19	Output 12	0.5	Low Side
20	Output 7	1	High Side
21	Output 6	1	High Side
22	Output 16	0.5	High Side
23	Input 4	-	High Side
24	Input 8	-	Low Side/ Analog
25	Input 9	-	Low Side/ Analog
26	Input 2	-	High Side
27	Input 3	-	High Side
28	Body CAN-L	-	-
29	Body CAN-H	-	-
30	CiA CAN-L	-	-
31	CiA CAN-H	-	-
32	ABH CAN-L	-	-

8.8.3 ABH CAN

A second CAN bus is available on the PSM (MPM):

The upfitter CAN (ABH CAN).

- High-speed CAN Class C
- Extended CAN identifier (29-bit)
 - Baud rate can be toggled between 250 kbit/s and 125 kbit/s
 - Signal format: Intel (LSB first)
 - All bus contents can be activated separately and independently of each other through parameterization:
 - Fleet Management Standard - FMS (transmission direction only)
 - ISO11992-2 and 3 (abridged)
 - Freely assignable messages (J1939)

 The Body and Equipment Guideline cannot describe in full the wide variety of capabilities of the PSM (MPM). You can obtain additional information in the PSM (MPM) on the Upfitter Portal (→ page 12).

NOTE

Based on a Daimler group-wide decision from the Autonomous Driving Ethics and Law Steering Committee, the Mercedes-Benz AG solely provides vehicle data to any third party and/or business partners through internal backends. Internal backends are the Mercedes PRO (MPRO) connect backend or the extended vehicle backend. External vehicle data transfer via the PSM (MPM) is no longer available as a regular option. The cases in which the PSM (MPM) is used for extended vehicle functionality but not for transmitting vehicle data to third-party backend are not affected by this regulation.

For customized solutions to transfer vehicle data directly to external backends, please contact: mpro-us-team@mbusa.com.

The Mercedes-Benz AG will continue to support for individual PSM request for usage inside the vehicle environment. For more information, please reach out to: www.UpfitterPortal.com.

8.9 Automatic start/stop system

The purpose of the automatic start/stop system is to reduce the emission values. If the automatic start/stop system is used, an enhanced on-board electrical system is used for stabilizing the on-board electrical system voltage. This includes an additional support battery and a modified fuse box.

To avoid dropping below the defined charge capacity of the battery, the system is automatically deactivated if the current consumption exceeds 140 A or if the charge state of the battery is low.

Automatic start/ stop system (code MJ8) is discontinued from MY21 Metris.

8.10 Electrical circuit diagrams

Electrical circuit diagrams can be made available to Upfitters as part of the ExpertUpfitter Program. As part of the ExpertUpfitter program please refer to www.UpfitterPortal.com.

Electrical circuit diagrams can also be called up in "Workshop Information System (WIS)" (→ page 12) Please see www.CVTekInfo.com.

8.11 Connectivity solutions

Mercedes me connect

Mercedes *me* connect

8.11.1 *Mercedes me connect* for personal use

Mercedes-Benz Vans offers *Mercedes me connect* for individual customers². *Mercedes me connect* provides an individual experience through the vehicle-integrated Communication Module (LTE)³ and the *Mercedes me connect* App. Your *Mercedes me connect* equipped Van will enhance your experience during purchase, service, and throughout your ownership. Your safety, comfort, and individual experience are our priority at *Mercedes me connect*.

Mercedes me connect consists of a multitude of services^{1,3}. Because your safety is our priority focus, we encourage you to make use of the Software Updates for your Van to always stay connected with our Customer Assistance Center in case of an emergency or a breakdown. Keep an eye on your Van's location status when parked by using the *Mercedes me connect* App anywhere and everywhere. Easily lock/unlock the doors remotely to stay reassured that your doors are locked at all times.

- 1 Models shown may include options/packages not standard on a Sprinter (as of MY19) or a Metris (as of September 2019 production, MY 20). Specifications are subject to change. Services require vehicle cellular connectivity and availability of vehicle GPS signal.
- 2 *Mercedes me connect* is generally available for the United States of America with the new Sprinter (as of MY 19) and new Metris equipped with a Communication Module (LTE) (as of September 2019 production, MY 20). Contact an authorized Mercedes-Benz Vans dealership for more information.
- 3 The availability of services in addition to the integrated Communication Module for Digital Services (LTE) depends on the network coverage of the mobile network provider. The Communication Module for Digital Services (LTE) is not available in the US Virgin Islands or Puerto Rico. The Communication Module for Digital Services (LTE) is equipped in the Sprinter (as of MY 19) and optionally equipped in the Metris (as of September 2019 production, MY 20). The availability of certain features may be impacted at the current time.

8.11.2 *Mercedes me connect* for business use

As a commercial customer you will now also have the opportunity to use *Mercedes me connect* for business purposes. The *Mercedes me connect* services for commercial customers ensure that you and your company remain connected to your Van at all times and from anywhere^{1, 2, 3}. With the *Mercedes me connect* App, you will always have the most up to date and important information about your Van right at the palm of your hands², which provides you with more efficiency and transparency to better benefit your company. Reduce your workload by taking advantage of online software updates, improve predictability for service needs with automated monitoring features, and stay up to date with remote services and real-time information.

As a company administrator for your company, you may reach out to your dealer and have your company registered for a new *Mercedes me connect* company profile. The dealer will be able to add your company vehicles to your company profile. Once set up, you, as a company administrator, will be able to manage company vehicles, users and services in the *Mercedes me connect* Portal. Additional users, such as drivers, will be able to use many of the *Mercedes me connect* services that are already available for personal use in the *Mercedes me connect* App and the Van¹.

⚠ WARNING

Using the *Mercedes me connect* App while driving will distract you from traffic conditions. This could cause you to lose control of the vehicle, which could result in an increased risk of endangering yourself and others, including the risk of accidents, personal injuries and death. In order to prevent distracted driving, the use of the *Mercedes me connect* App is not permitted while operating a motor vehicle. Please follow all applicable federal, state and local laws and restrictions and observe the legal requirements of the country in which you are currently located.

- i** For further information on service availability and eligibility of your Van^{1, 2, 3} visit the following link:
www.mbusa.com/en/legal-notice/connect-ed-vehicle
 or contact your dealer.

8.12 Telematics

The table below lists the abbreviations used in the field of telematics.

Abbreviation	Meaning/description
HU	Head Unit
DVI	Digital Visualization Interface
CAN	Controller Area Network
CAR PC	Control unit or PC installed in the vehicle
TMDS	Transition-Minimized Differential Signaling
RGB signal	Red, green and blue signal
PSM	Parameterizable Special Module (also known as MPM)
DAB	Digital Audio Broadcasting
LTE	Long Term Evolution
GPS	Global Positioning System
AM/FM	Amplitude modulation/frequency modulation

9.1 Center of gravity

The overall height of the center of gravity (vehicle with complete equipment/body and without load) must be kept as low as possible.

The position of the center of gravity in the longitudinal direction of the vehicle is specified with reference to a vehicle axle.

The center of gravity height is specified with reference to the roadway.

Mercedes-Benz recommends that the upfitter have the position of the center of gravity checked by an approved and experienced testing institution.

Mercedes-Benz recommends that you have the position of the center of gravity checked by a recognized and experienced testing institution (e.g. DEKRA, Technical Inspection Association (TÜV) etc.). The department responsible can provide any support you may need, see Chapter 2.1 Advice for upfitters (→ page 10).

If the center of gravity is determined by the upfitter, the procedures described under Chapter 9.1.1 Determination of the center of gravity in the x-direction (→ page 126) and Chapter 9.1.2 Determination of the center of gravity in the z-direction (→ page 128) must be followed and services of qualified persons must be used so as to achieve realistic and useful results.

Likewise, the web-based “Vehicle Center of Gravity and Axle Weight Calculator” provided by NTEA may be helpful. Mercedes-Benz does not take responsibility of the accuracy of the calculated values by the NTEA web-based calculator, www.ntea.com/weightcalculator.

The vehicle must be measured in a load condition appropriate for its intended purpose.

! NOTE

Practical determination of the center of gravity position in the x and z-directions may only be carried out by appropriately qualified staff using suitable and calibrated vehicle scales.

In order to reduce measuring errors, each measurement value should be determined at least three times and the average should be calculated from these three values.

9.1.1 Determination of the center of gravity in the x-direction

CoG coordinates in x-direction (front/rear axle load distribution)

Procedure:

- ▶ In the first series of measurements, the vehicle is to be weighed with the complete attachment or body and without payload.
- ▶ In the second series of measurements, the vehicle is to be weighed with the complete attachment and/or body and with a payload appropriate for its intended purpose, taking into account the permissible gross mass and the permissible axle loads.
- ▶ For the measurements, the tire pressure at all wheels is to be set to 6 bar.
- ▶ Completely fill all fluid reservoirs (fuel tank, washer fluid reservoir and, if installed, hydraulic tank, water tank etc.).
- ▶ Shut off the engine on the scales, shift the transmission to neutral position and release the brakes.
- ▶ The vehicle must be parked horizontally on level ground for weighing.
- ▶ First weigh the individual axle loads (front and rear axle loads) and then the gross vehicle mass.
- ▶ Using these measurements, the position of the center of gravity in the longitudinal direction of the vehicle can be calculated using equations (3) and (4).
- ▶ Use (2) to check the results from (3) and (4).

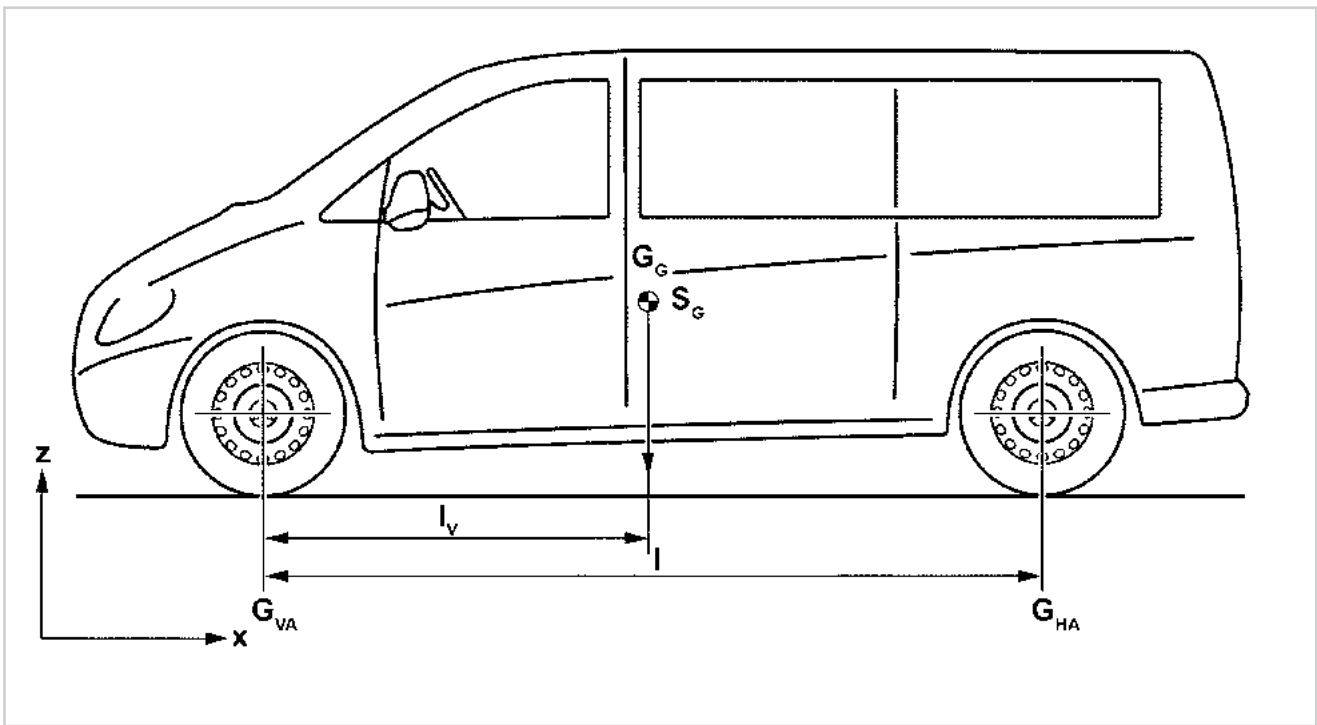

N60.00-2313-00

Figure: Axle load calculation

$$G_G = G_{HA} + G_{VA} \quad (1)$$

$$l = l_V + l_H \quad (2)$$

Calculation of the center of gravity in the x-direction

$$l_V = \frac{G_{HA} \times l}{G_G} \quad (3)$$

$$l_H = \frac{G_{VA} \times l}{G_G} \quad (4)$$

Weights:

G_G Gross mass of vehicle

G_{VA} Front axle load of empty vehicle
(specification or weighing of the chassis in question)

G_{HA} Rear axle load of empty vehicle
(specification or weighing of the chassis in question)

Dimensions

l_V Distance of overall center of mass of empty vehicle from front axle

l_H Distance of overall center of mass of empty vehicle from rear axle

l Wheelbase

S_G Overall vehicle center of gravity

i The wheelbase "l" is defined by the vehicle model designation (see order) or must be determined by means of a length measurement according to DIN 70020, Part 1.

9.1.2 Determination of the center of gravity in the z-direction

CoG coordinates in z-direction (height of center of gravity h_S for the overall vehicle)

For determination of the overall center of gravity height of the vehicle h_S by the upfitter, Mercedes-Benz recommends the following procedure after completion of the vehicle:

After conversion, the vehicle should be weighed on a plate-type scale or suitable wheel load scale in two different drive positions in succession. Here, the axle loads measured when the vehicle stands horizontal and level (G_{VA} and G_{HA} , see Chapter 9.1.1 Determination of the center of gravity in the x-direction (→ page 126)) and the axle loads for an axle raised by h' (Q_{HA} or Q_{VA}) must be determined. The lift height h' should be as large as possible in accordance with the front and rear overhang angle of the vehicle (also known as the angle of approach/departure). The target value is $h' > 600$ mm / 23.62 in.

In order to reduce measuring errors, at least six individual measurements must be performed for each vehicle axle when measuring the axle load: three per axle when the vehicle is in a level state and three when an axle is raised. Based on the three measurements in each condition, an average should be calculated for each axle. The mean value must be calculated from these three values and this mean value must then be used when calculating with equations (5) to (7). In order to improve the accuracy of the final result, the axle load change should be determined both with a raised rear axle and with a raised front axle.

! NOTE

In order to avoid erroneous measurements, please note:

- When weighing with the vehicle level, the vehicle must be exactly horizontal. Any height differences between the axles caused by the scales must be compensated for accordingly.
- Both axles must be blocked to prevent suspension jounce and rebound when raising to the required lift height.
- When raising, the left and right sides must be raised in parallel.
- No part of the vehicle may bottom out when raising to the required lift height.
- All vehicle wheels must be able to roll: Gearshift system in neutral position, all brakes including parking brake released, chocks placed at a sufficient distance from the wheels if necessary.
- All tires must be set to a tire pressure of 6 bar.
- For turning (in order to weigh the other axle), move the vehicle under its own power so that any stresses in the vehicle are relaxed.
- Make sure that no objects inside the vehicle can move during the measurements.
- Also ensure that all fluids are topped up.

If the vehicle suspension cannot be blocked owing to its design or space restrictions, further axle load measurements must be taken at different raised positions (e.g. 600 mm / 23.62 in, 700 mm / 27.56 in and 800 mm / 31.50 in). Here, errors can again be limited by averaging. The center of gravity height is equal to the arithmetic mean of the individual center of gravity heights for each raised position.

Example of procedure

- ▶ In the first series of measurements, the vehicle is to be weighed with the complete attachment or body with axle blocking and without payload.
- ▶ In the second series of measurements, the vehicle is to be weighed with the complete attachment and/or body with axle blocking and with a payload appropriate for its intended purpose, taking into account the permissible gross mass and the permissible axle loads.
- ▶ Inflate the tires up to a tire pressure of 6 bar.
- ▶ Completely fill all fluid reservoirs (fuel tank, washer fluid reservoir and, if installed, hydraulic tank, water tank, etc.) and load or attach all the gear and equipment required for operation.
- ▶ Shut off the engine on the scales, shift the transmission to neutral position and release the brakes.
- ▶ Position the vehicle with the rear axle (HA) at a horizontal and level position on the scales and determine the axle load.
- ▶ Raise front axle (VA) by the value h' , at least 600 mm / 23.62 in. Increasing the height h' while taking the other boundary conditions of the vehicle into account improves the final result. The value h' must be determined for all individual measurements with raised axle and should be identical wherever possible. As an alternative to measuring the raised height h' , the angle α between the wheel hubs can be determined.
- ▶ Determine the resulting axle load shift Q_{HA} at the rear axle on the scales.
- ▶ Lower the vehicle and perform lifting measurements 2 and 3. Between all the individual measurements and to turn it around (in order to weigh the other axle), move the vehicle under its own engine power so that any stresses in the vehicle/chassis are relaxed.
- ▶ After the 3rd measurement, lower the vehicle, turn it around and carry out corresponding measurements on the front axle (initially G_{VA} with the vehicle level, and then Q_{VA} with the rear axle raised by height h').

- ▶ Using the calculated values, the height of center of gravity can be calculated using equations (5) to (7).
- ▶ When calculating using the equations (3) to (9), all length measurements must be used in millimeters (mm) and all weights must be used in decanewtons (1 daN = 10 N).
 $G = 1 \text{ daN} = 10 \text{ N} = 2.25 \text{ lbf}$ is the weight force corresponding to the mass $m = 1 \text{ kg} = 2.2 \text{ lbs}$.

NOTE

Practical determination of the center of gravity height may only be carried out by appropriately qualified staff using suitable, highly accurate and calibrated measuring equipment and measurement tools.

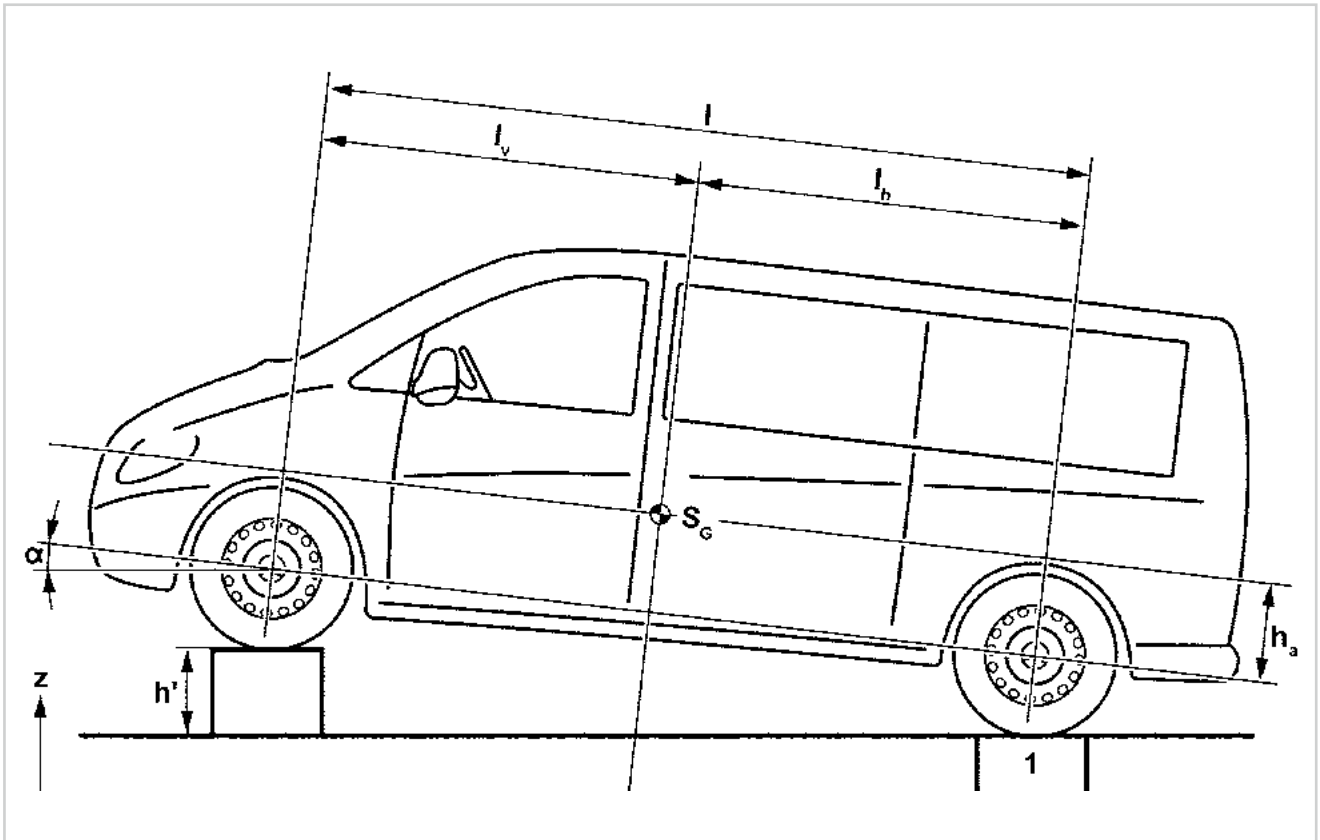

N60.00-2314-00

Figure: Determining the height of the center of gravity

$$h_S = h_a + r_{stat} \quad (5)$$

- h' Height by which the vehicle was raised
- S_G Overall vehicle center of gravity
- 1 Weighing device

- r_{stat} Loaded tire radius
- Q_{VA} Front axle load with vehicle raised at rear
- Q_{HA} Rear axle load with vehicle raised at front
- h_S Height of center of gravity above roadway
- h_a Height of center of gravity above wheel center

i The wheelbase "l" is defined by the vehicle model designation (see order) or must be determined by means of a length measurement according to DIN 70020, Part 1.

Formulas for raised front axle:

$$h_S = \left(\frac{l}{h'} \times \frac{Q_{HA} - G_{HA}}{G_G} \times \sqrt{l^2 - h'^2} \right) + r_{stat} \quad (6)$$

Formulas for raised rear axle:

$$h_S = \left(\frac{l}{h'} \times \frac{Q_{VA} - G_{VA}}{G_G} \times \sqrt{l^2 - h'^2} \right) + r_{stat} \quad (7)$$

! NOTE

The calculated center of gravity must not exceed the limit values specified under Chapter 4.1.2 Maximum permissible position of the center of gravity (→ page 47).

10.1 Vehicle data

 Further technical data for the vehicle can be obtained:

- From your contact persons, see Chapter 2.1
Advice for upfitters (→ page 10)
- From the vehicle configurator at
www.mbvans.com

A		Flaps.....	69
Accident prevention	22	Fuel system.....	72
Additional assemblies	84	Functional reliability.....	110
Adhesive films	45	Fuses	53
Advice for upfitters.....	10	I	
Air suspension	64	Identification data	33
Antenna.....	109	Identification plate	33
Anti-corrosion protection	57	Illumination.....	105
Attachment above cab	85	Interior	76
Attachments	85	Interior noise	83
Auxiliary heating.....	84	L	
Axle loads.....	50	Limit values for electrics.....	53
B		Limit values for electrics/electronics	53
Basic vehicle (modifications)	61	Limit values for the basic vehicle	47
Batteries.....	42	Limit values for the body-in-white	52
Battery	97	Limit values for the suspension.....	50
Body	66	Limit values for tire sizes	51
Body-in-white	66	M	
Body-in-white, modifications	52	Maintenance and repairs	41
Brake hoses	54	Mercedes me connect.....	124
Brake system	62	Mini-PLC.....	121
C		Mobile communications systems	109
Cables and lines	54	Model code	26
Calculations	126	Modifications to the basic vehicle	61
Camper van bodies.....	93	N	
Center of gravity calculation.....	126	Noise level	83
Clearance dimensions, trailer coupling.....	90	O	
Conventions	7	Operational safety	9
Cooling.....	75	P	
Copyright	9	Painting work.....	59
D		Paintwork	59
Damage prevention	54	Parameterizable special module (PSM, MPM).....	119
Dimensions	30, 47	Partition wall.....	67
Drivetrain	72	Preservation work	59
E		Product liability	17
Electrical interfaces	100	Product safety	17
Electrics	95	Programmable logic controller (PLC).....	121
Electronic Stability Program (ESP®)	110	Propeller shafts	75
EMC	96	PSM (MPM) functions.....	120
Engine air intake.....	75	Q	
Engine peripherals.....	72	Quality system.....	24
Exhaust system	73	F	
F		Fenders	70

R		W	
Reducing interior noise	83	Weights	30
Refrigerated vehicle bodies	92	Weight specifications	30
Refrigerated vehicles	92	Welded connections	38
Repair	41	Welding work	55
Reprocessing of components	23	Wheels/tires	64
Rescue card/QR code rescue sticker	34	Wheel wells	70
Roof	52		
Roof height increase	94		
Roof loads	52, 70		
Roof luggage racks	85		
S			
Safety equipment	77		
Safety-relevant features	17		
Seats	91		
Selecting the chassis/basic vehicle	26		
Service lift support points	49		
Shock absorbers	62		
Soundproofing	40		
Spare wheel	65		
Special equipment	44		
Steerability	47		
Suspension	61		
T			
Threaded connections	37		
Tire load capacity	30		
Tire pressure monitoring	116		
Tires	36		
Traceability	18		
Trademarks	19		
Trailer coupling	90		
U			
Underfloor paneling	70		
Upfitter Portal	12		
Upfit Vehicle Release	42		
V			
Vehicle center of gravity	126		
Vehicle dimensions	47		
Vehicle identification data	33		
Vehicle modifications	29		
Vehicle safety	8		
Vehicle stability	35		
Ventilation	84		

List of abbreviations

Abbreviation	Explanation
ABH	Body manufacturer or upfitter
ABS	Anti-lock Brake System
AGM	Absorbent glass mat, design of lead-acid batteries
BEG	Body and Equipment Guidelines
BM	Model designation
BR	Model series
DIN	Deutsches Institut für Normung/"Deutsche Industrie-Norm" (German Standards Institute/"German Industry Standard")
EMC	Electromagnetic compatibility
ESP®	Electronic Stability Program
FMVSS	Federal Motor Vehicle Safety Standards
ISO	International Organization for Standardization
KTL	Cathodic dip painting
LDS	Rotary light switch
MBN	Mercedes-Benz Standard (company standard)
OBD	On-Board Diagnosis
PSM	Parameterizable special module (MPM)
SAM	Signal acquisition and actuation module
TPMS	Tire Pressure Monitoring System
UIS	Upfit Impact Study
VDA	German Association of the Automotive Industry
VIN	Vehicle identification number
WIS	Workshop Information System

